

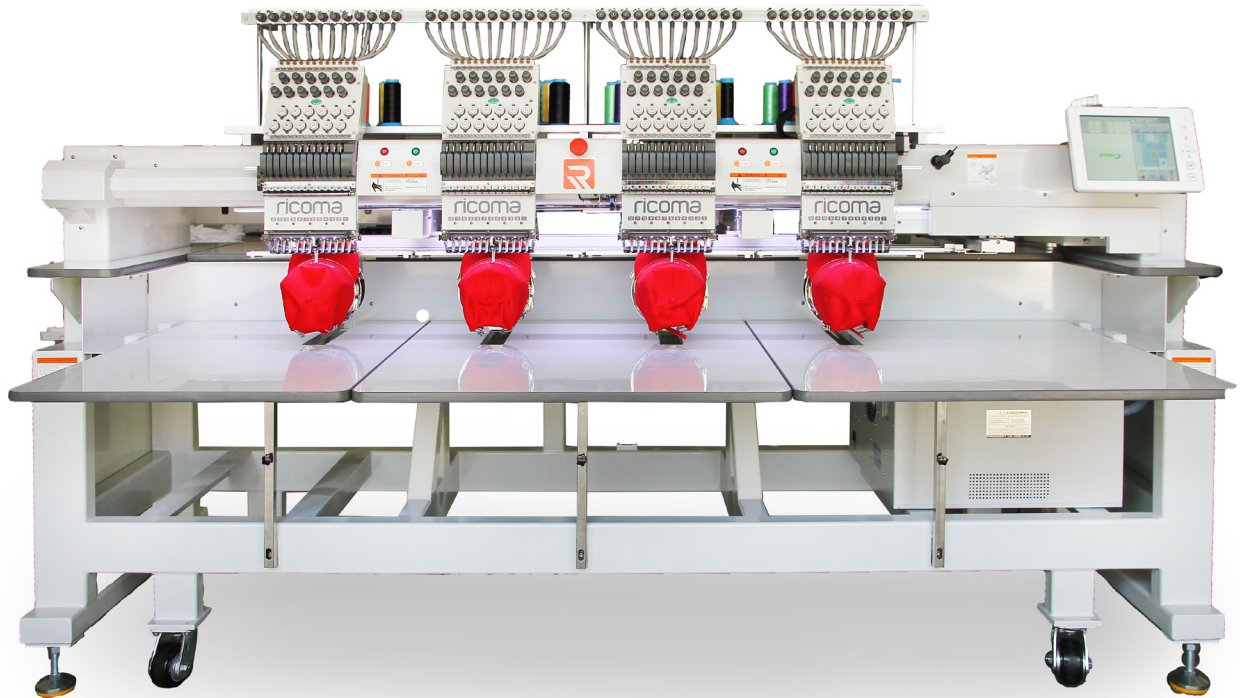

QUICK START GUIDE: CHT2 MULTI-HEAD



RICOMA INTERNATIONAL CORPORATION

3450 NW 114th Ave., Miami, FL 33178
Telephone: (305) 418-4421 | Toll Free: 1-888-292-6282
Fax: (305) 418-5036 | Email: service@ricoma.us
www.ricoma.us

Copyright 2018 Ricoma International Corporation
All rights reserved

TABLE OF CONTENTS

GETTING STARTED: MACHINE OVERVIEW

Leveling the machine	6
Turning on the machine – power cord connection	7
Security lock	7
Machine head indicator lights	8
Start/stop button in between metal covers	8
Adjusting the position of the panel	9
Emergency stop button	10

THREADING

How to replace a spool	10
Preparing your machine for threading	11
Threading the machine from start to finish	12

INSTALLING THE NEEDLE

Selecting a needle	14
How to install the needle	14

INSTALLING THE BOBBIN

The anatomy of the bobbin case	15
Inserting the bobbin	16

HOOPS AND BRACKETS

Cap rings and cap attachments	17
How to remove the cap driver	18
How to install the cap driver	18
Flat hoops and brackets	19
How to attach the flat frame bracket	20
How to remove the flat frame bracket	20
How to insert the hoop into the machine	20
How to remove the hoop from the machine	21

EMBROIDERING WITH THE EXTENDED TABLE

How to install the extended table	21
Attaching the sash frame	23

HOOPING

Finding the center of your design for a left-chest logo	23
Hooping a polo or golf shirt	24
Hooping a hoodie or jacket	25
Hooping the front or sides of a cap	26
Hooping the back of a cap using a round hoop	27

CONTROL PANEL OVERVIEW

Full embroidery process from start to finish	29
How to change your embroidery status	30
Design menu	30
Design settings menu	34
Color sequence settings	37
Design tracing	39
How to adjust embroidery speed	39
Emb mode menu	40
Start-up menu/Color change mode	41
Manual color change/needle display	41
Trimming	42

MAINTENANCE

Oiling/Lubrication	42
Care of the bobbin case/rotary hook area	44

COMMON ERRORS

Resolving a thread break	45
Replacing a needle	46
Bobbin running out	46
Emergency stop error	47
No needle error/color change error	47
Motor fault error/Main axis error	47
Hook timing	48

TENSION

Tension	49
Adjusting the top thread tension: Spring lever	50
Adjusting the top thread tension: Tension knobs	50

TABLE OF CONTENTS

Adjusting the bobbin tension	51
Other factors that affect tension	52
THREAD BREAKS	
Reasons why thread breaks occur	53
Thread break prevention	53
Thread break troubleshooting	54
NEEDLES	
Anatomy of the needle	55
How long do needles last?	55
How do I know when to change a needle?	56
Why do needles break?	56
Blade sizes	56
Needle finishes	57
Types of needlepoints	57
The difference between sharp point and ball point needles	58
The relationship between needles and threads	58
THREAD	
The bobbin	59
Types of bobbin sides	60
Bobbin fiber choices	60
Top thread fiber choices	61
STABILIZER	
Common stabilizer weights	63
Cut-away	64
Tear-away	64
Specialty backing	64
Topping	64
Poly mesh backing	65
Fusible backing	65
Foam	65

EMBROIDERY TECHNIQUES

Backing and needle recommendations	65
Hooping placement recommendations	67
Specialty hoops	69
Cap selection	70
Cap digitizing	70
Cap sewing tips	70

GETTING STARTED: MACHINE OVERVIEW

Leveling the machine

Leveling your embroidery machine is essential, as this step will ensure your machine is secured into place. Skipping this step may result in injury, loss of registration of your design and other issues.

Before leveling your machine, make sure the four level pegs are attached to the stand legs.

See Figure 1.

To level your machine, take all four level pegs on your machine stand and rotate them clockwise by hand until they reach the floor. Once the pegs have reached the floor, rotate each nut clockwise using the provided black wrench. Do NOT skip this important step, as this will ensure the pegs are fixed to the ground.

Once you have tightened all four pegs, the wheels on the machine will lift, immobilizing it. Last, confirm the machine is secure and is no longer able to move. Refer to the leveler on the bottom right and left of the machine to confirm that the machine has been properly leveled. If the bubble is in the center of the lines, then you have correctly completed this step. **See Figure 2.**



Figure 1



Figure 2

Turning on the machine – Power cord connection

The CHT2 runs on 220 volts. If you are in a country with a 220-volt output, you can plug the machine directly into an outlet to power it on.

If you're in the U.S. or a country with a 110-volt electrical output, you will need to use the transformer included with your machine to convert the electrical output from 110 volts to 220 volts in order to operate the machine properly.

If you're in a country with a 110-volt output, follow these steps to correctly turn on your machine.

1. Connect the plug on the machine's box to the transformer.
2. Plug the transformer into an electrical outlet.
3. Turn on the transformer. **See Figure 3.**
4. Flip the orange switch on the machine's box. See **Figure 4.**

Note: The switch should be flipped toward the back of the machine.

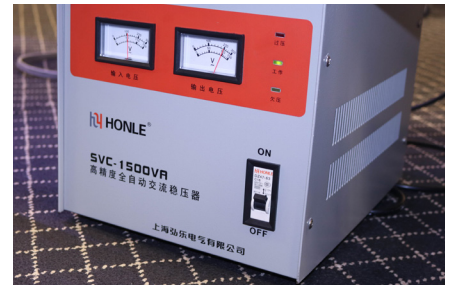

Figure 3



Figure 4

Security lock

Your CHT2 comes with security locks in between the machine heads to prevent any damages during shipping. **See Figure 5.**

Before operating your machine, be sure to remove the locks. Keep these locks handy in case you plan on moving your machine to a new location in the future.

To locate the security lock, slide off the magnetic metal cover between the heads. **See Figure 6.**

To remove the security lock, loosen its screws using a 4 mm Allen wrench. You will find a set of Allen wrenches in your toolkit. Once the security lock is removed, return the metal cover to its original position.



Figure 5



Figure 6

Machine head indicator lights



Figure 7

The machine head indicator lights are located on the top right of each machine head. **See Figure 7.**

During working status, the machine head indicator lights are green. If you encounter a thread break while embroidering, the indicator light will flash red.

Start/stop button in between metal covers



Figure 8

On the metal cover in between the machine's heads, you'll find start and stop buttons to make multi-head operation more efficient. The red button is the stop button. The green button is the start button. These buttons serve the same function as the start and stop buttons on your panel that allow you to rewind and forward through your design. **See Figure 8.**

To rewind slowly through your design, first press the red button to stop the machine. Then, hold the red button until you have reached the area where you want to begin stitching again. Last, tap the red button again to stop the machine from rewinding. Next, locate the switch on the machine's head. This will be located underneath the machine head indicator light. Next, flip the switch underneath the indicator light upward. **See Figure 9.**



Figure 9

This action will trigger a red blinking light, and tell the machine it's in repair mode. **See Figure 10.**

You can now press the green button and the design will start again and stitch over the missed part.

NOTE: If you don't flip the switch up, the machine will fast forward through the design and will not stitch until the point where the thread break occurred. Keep in mind: Rewinding the design on one head will rewind the design on all heads.

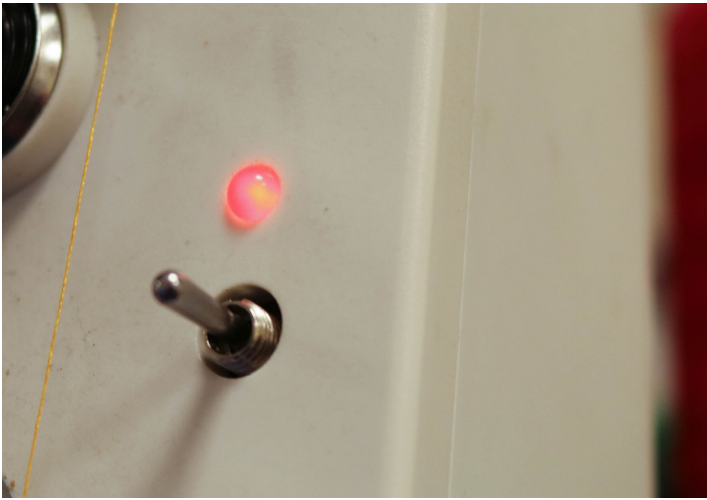

Figure 10

To fast forward slowly through your design, press the green button only after you have pressed the red button. Then, press the red button to stop the machine from fast forwarding. Press the green button again to begin stitching from the desired point.

Note: It is unnecessary to flip the switch if you are fast forwarding through designs.

Adjusting the position of the panel

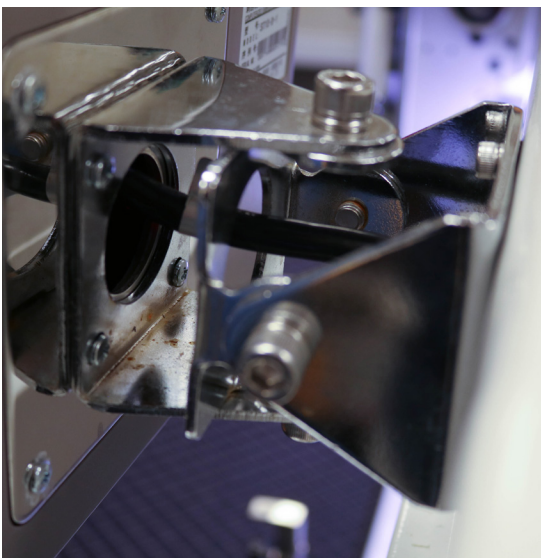

Figure 11

First, be sure to carefully remove the plastic wrap that protects the panel. After removing it, you will find four Allen screws, which will allow you to adjust the placement of the panel. **See Figure 11.**

Your touch-screen panel can be adjusted in two ways: up and down or from side to side. To adjust the panel, use the 5 mm Allen key included in your toolbox. To move the panel from side to side, loosen the two Allen screws on the top and bottom. Then, adjust the panel assembly until it's facing the desired position. Next, tighten the screws using the 5 mm Allen key. To move the panel up or down, loosen the two Allen screws on the right and left. Next, adjust the panel assembly until it's facing the desired position. Last, tighten the screws using the 5 mm Allen key.

Keep in mind: This step is important, as you need to position the panel away from the machine head in order to avoid the head hitting the panel when it moves to the far right.

Emergency stop button

In case of an emergency, press the red emergency stop button located on the metal cover in between the machine's heads. Hitting this button will kill the power immediately. To restart the machine, rotate the knob clockwise following its directional arrows. The knob will then release, allowing the machine to be powered on again. Keep in mind, you need to turn your machine back on to commence. To turn your machine back on, click on the orange reset button located next to the power switch. Then, flip the power switch back on. **See Figure 12.**



Figure 12

THREADING

How to replace a spool



Figure 13

Because your machine comes pre-threaded, you will only need to replace the spools at first rather than threading the machine from the very beginning. To do so, clip the thread from the existing thread spool. Make sure you clip the thread right above the spool and not inside the thread path. **See Figure 13.**

Then, replace the existing spool with a new spool. Next, take the loose end of the thread from the existing spool and tie it to the loose end of the new thread in a simple knot. **See Figure 14 and 15.** Repeat this process on all spools before proceeding.

Now, go to the front of your machine and make sure the threads are separated on their individual thread paths. Next, grab the thread from the presser foot, and pull each thread carefully all the way through until you no longer see any of the old thread.

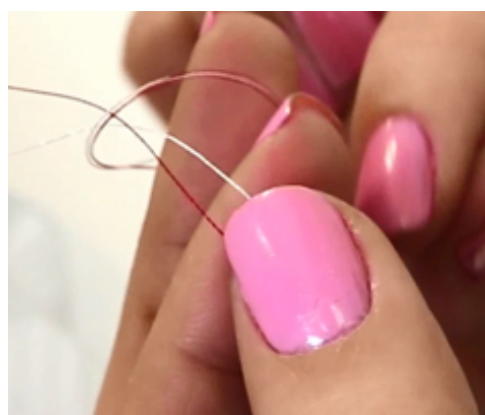

Figure 14

While you pull the thread, you'll see the new thread and the knot you created traveling through the thread path. Continue to pull until you see the knot you created reaches past the needle bar. Now, clip the thread right above the knot, and repeat the process on all remaining needles. Once you have completed all needles, it's time to thread the needle. Pass the thread through the eye of

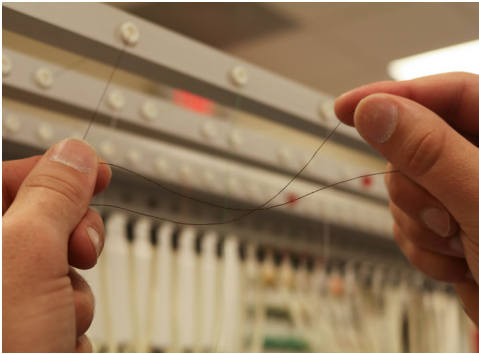

Figure 15

the needle starting from the front to the back. Once you made sure your thread has gone through the needle, pass the thread down the presser foot. Now, you can rest your thread on the spring. You should leave about two inches of thread hanging and trim the excess.

Keep in mind: The color spools will need to be placed in the same order on all heads. For example, if you place the white thread on needle 1 on one head, you need to place the white thread on needle 1 on the remaining heads as well.

TIP: Mastering basic knot tying will save you time and materials.

When tying new threads to old threads while replacing a spool, you want to create a knot that will pull easily through the needle's eye.

Preparing your machine for threading



Figure 16

The thread tubes will be used during the threading process. These tubes carry the thread from the thread rack to the machine's head. Your machine comes pre-threaded with these tubes in place.

In the future, you may need to remove the tubes to thread your machine from scratch. To reattach them, attach one end of the tube to the slot just below the top thread tension knob. Then, attach the other end of the tube to the slot on the machine's

head. You may find it easiest to work from the center out. Guide yourself by counting the slots on the top and bottom to make sure you are attaching the tubes to their corresponding slots. The first slot on the top should go with the first slot on the bottom and so forth. **See Figure 16.**

Your welcome kit contains two boxes of embroidery thread. You will need 15 spools of thread for each of the machine's heads. If you haven't done so yet, remove the wrappers on the provided thread spools.

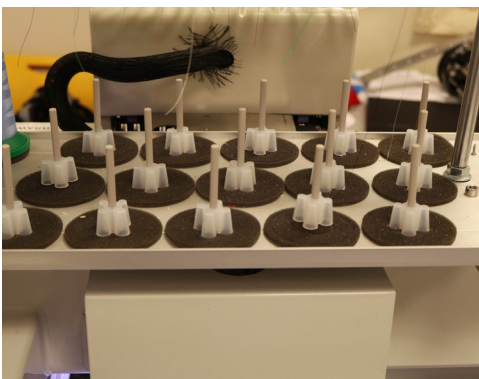

Figure 17

To release the tail of the thread, unsnap the base of the cone, and unwind until the thread is completely out of the base.

To begin threading your machine, place each thread spool onto the spool pins. The spool pins are the 15 pins secured with grey foam and a clear plastic reel behind each of the machine heads. Before positioning the spools, **see Figure 17** to view which thread spool pin corresponds with each needle.



Figure 18

Before threading, you should be familiar with the thread path. The back row of thread will be threaded through the back metal rack. The middle row of threads will be threaded through the middle metal rack. And the front row of threads will be threaded through the front metal rack. **See Figure 18.**

TIP: If possible, try not to place colors that are similar, such as black and navy blue, close to each other. This could lead to accidental misuse of similar color.

Threading the machine from start to finish

To thread your machine from the very beginning, follow these simple steps. You will use the eyelets on the thread rack to guide the thread in a straight path toward the first tension knob. Make sure the thread passes through each eyelet. You will need to thread the first three cones in order from back to front. Then, repeat this order with the next three cones and so forth. **See Figure 19.**

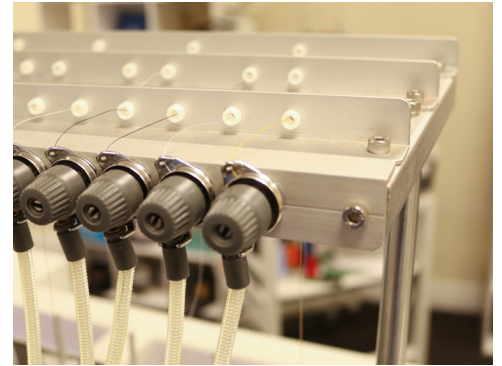

Figure 19

1. Thread each spool through the eyelets on the upper thread rack until they reach the top tension knobs. **See Figure 19.**
2. Next, pass the thread through the small eyelet located behind the first tension knob. Position the thread to the right side of the top tension knob in between the tension disks, making sure the thread is inside the tab at the 3 o'clock position. To ensure you've completed this step correctly, make sure the metal plates on the tension knob are touching after you've positioned the thread. **See Figure 20.**
3. Unhook the thread tube from each side. Next, using the included threading tool from your toolkit, hook the thread to the end of the tool and feed the thread through the plastic tube. Once the thread has been fed through the tube, unhook the thread. **See Figure 21.**
4. Reattach the thread tube to each end.



Figure 20

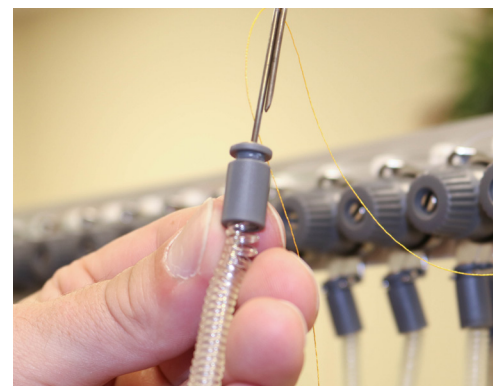

Figure 21

5. Pass the thread through the clip located just above the top tension knobs. Be sure to gently pull the clip up with your finger, rather than just sliding the thread under the clip to avoid damaging the thread and threading the machine incorrectly. **See point A in Figure 22.**
6. Next, pull the front disk of the tension knob toward you, and slip the thread to the right side of the knob. You will know which path to follow for each needle by using the numbers as guides. The photo displays the thread path for needle 14. **See point B in Figure 22.**
7. Locate the post right above the corresponding thread break wheel (these are the white wheels on the machine's head.) Pass the thread through the left side of the post. **See point C in Figure 22.** Then, guide the thread to the right and wrap it around the thread break wheel. **See the path from point C to E in Figure 22.** Make sure you make one full clockwise rotation until the thread exits through the left side of the bottom post. **See point E in Figure 22.**
8. Place the thread under the bottom clip by pulling the clip up. Slide the thread underneath. **See point F in Figure 22.**
9. Next, you will thread the check spring and the lever arm. Begin by lifting the lever to place the check spring into threading position if it isn't already. Now, coming down from the right side, pass the thread over the outer right side of the rollers and then in through the opening in the center. **See point G in Figure 23.** Next, pass the thread through the spring from the right to the left. **See point H in Figure 23.** Then, take the thread and pull it through the opening in the center and out over the outer left side of the rollers. Continue pulling the thread up until you reach the lever arm. **See point I in Figure 23.**
10. Now, pass the thread through the opening of the lever arm from the right to the left. **See point I in Figure 23.** Then pass the thread back down until it runs through the ceramic eyelet. **See point J in Figure 23.** Continue running the thread down the same path until it passes through the following ceramic eyelet. **See point K in**



Figure 22

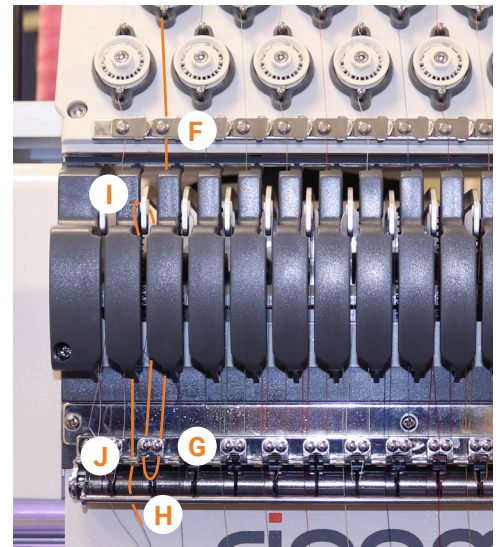

Figure 23



Figure 24

Figure 24.

11. Now it's time to thread the needle. Pass the thread through the eye of the needle from the front to the back. To ensure your needle is placed correctly, make sure the curved side is facing the back. Then, pass the thread through the presser foot. **See point L in Figure 24.**
12. Now, you can pull the thread back up, and rest your thread on the spring until you're ready to embroider. We recommend leaving one to two inches of thread hanging and trimming the excess. This is optional, but will eliminate the need to snip the thread tail that will remain after the first stitch is made while the thread tail is still held on the spring. **See Figure 24.**
13. Last, take a step back and look at the front of the machine to make sure that all needles appear to be threaded correctly. If they seem to be uniform, you are ready to stitch a test pattern.

TIP: *If you run out of thread completely on a needle bar, re-thread, matching the thread path to a correctly threaded neighboring needle bar.*

INSTALLING THE NEEDLE

Selecting a needle

Choosing the right needle is important to ensure quality stitches. Embroidering with a needle that is too small or too big for the thread and/or fabric may result in thread breaks or skipped stitches. There are three things to consider when choosing the right needle for the job: finish, size and point. DBxK5 is an established standard system for machine embroidery. This style needle has a medium point with a larger eye, which allows the thread to flow smoothly and helps reduce thread breaks. Its only downfall is that it is slightly less durable due to its thinner eye wall. A size 75/11 sharp point needle will work for most embroidery projects. However, a general rule of thumb is to use ball point needles for knits and sharp point needles for woven fabrics.

Tip: *In order to puncture the smallest hole possible, always use the smallest needle you can get away with. Heavier materials cause the needle to bend, or deflect. This causes needle breaks, thread breaks, missed stitches and other issues. We control the needle deflection by slowing down the speed of the machine and/or changing the size of the needle.*

How to install the needle

When changing a needle, make sure the scarf of the needle is facing away from you and toward the machine. When inserting the needle make sure it is completely straight and not slanted. If the needle is

not positioned correctly, the machine will not work properly, and the needle will break.

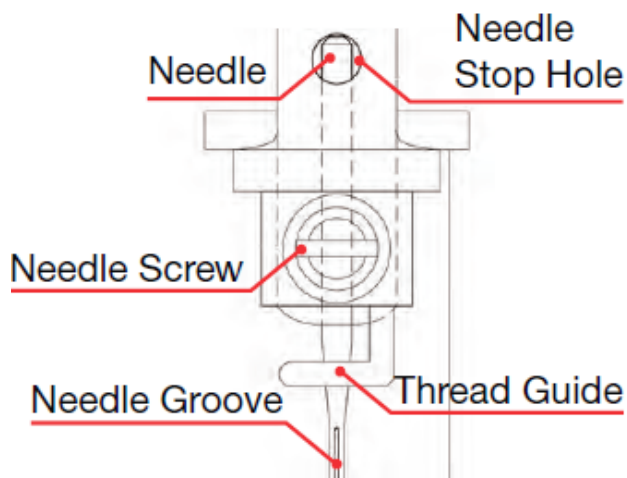

Figure 25

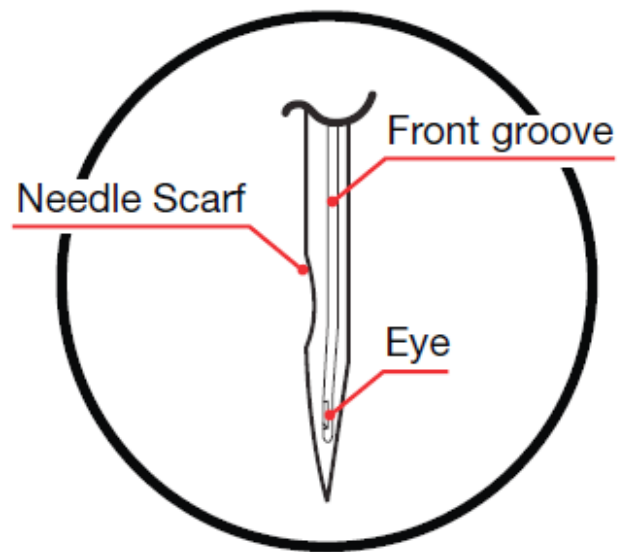

Figure 26

Tip: When changing the needle, set the needle aside while you determine whether a fresh needle corrects the problem. If you determine that the needle was the likely cause of the problem, discard in an old medicine bottle or other sharp-safe container.

INSTALLING THE BOBBIN

The anatomy of the bobbin case

Before threading the bobbin and inserting the bobbin into the machine, be familiar with the parts of the bobbin case that will be referenced.

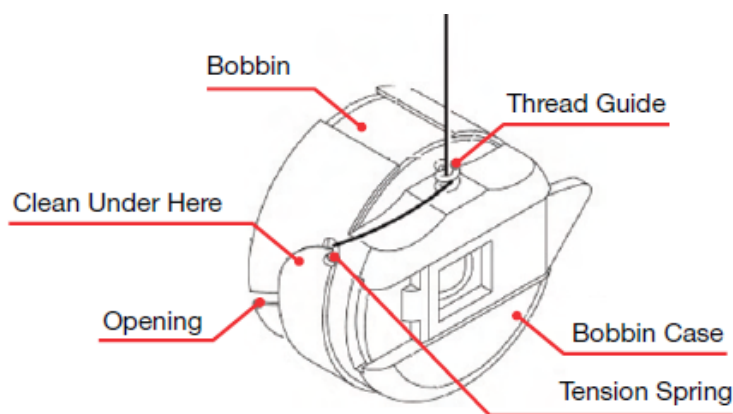

Figure 27

Inserting the bobbin

1. If you haven't done so yet, remove the bobbin case from the machine's bobbin housing unit. To do so, simply lift the latch and pull the bobbin case toward you.
2. Pull out the empty or nearly empty bobbin and discard or rewind.
3. Insert the bobbin into the bobbin case, making sure the thread is running clockwise. **See Figure 28.**
4. Pass the thread through the bobbin case slit. **See Figure 29.**



Figure 28



Figure 29

5. Pull the bobbin thread under the tension arm, making sure the thread exits at the notch on the other end. **See Figure 30.**
6. To ensure the bobbin is placed correctly, turn the bobbin case to the other side, and pull on the thread. The bobbin thread should still be running clockwise in this direction, and you should see the letters rotating clockwise. **See Figure 31.**



Figure 30

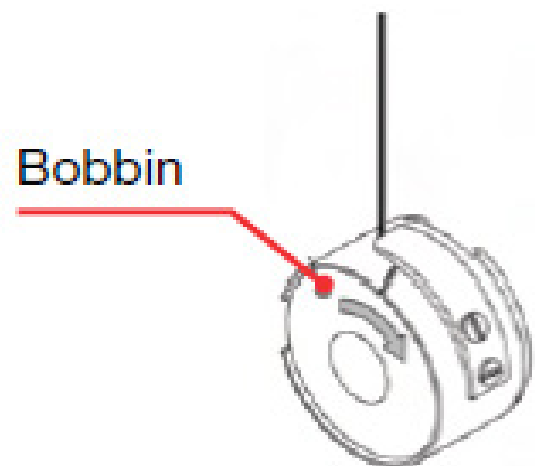

Figure 31

7. Wrap the thread around the small pigtail on the bobbin case. **See Figure 32.**
8. Grab the bobbin case while lifting the latch, and insert it into the machine. Make sure the thread tail is no longer than 3 inches. A longer tail can wrap around the shaft and create a build-up of thread. **See Figure 33.**



Figure 32



Figure 33

HOOPS AND BRACKETS

Cap rings and cap attachments



Figure 34 - Cap Driver

When sewing caps, you will need to use the following materials: the cap driver, the cap station, a cap ring, a blank cap and backing (usually tear-away).

The cap driver is the accessory that is mounted on the machine. **See Figure 34.** This tool holds the cap and cap ring during the sewing process.

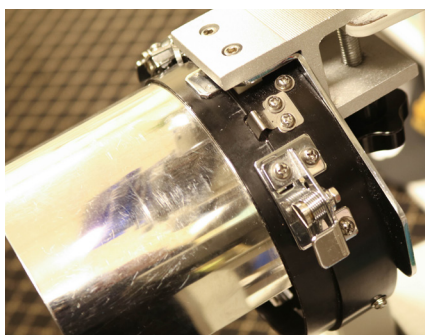

Figure 35 - Cap Station

The cap station is the tool that holds the cap ring (the cap hoop) while hooping. The cap station should be mounted on your machine stand or on a sturdy table. **See Figure 35.**

Once you have mounted the cap station, you can attach the cap ring to the cap station to begin hooping.

The cap ring is the hoop for your caps. **See Figure 36.** This ring can be adjusted depending on the thickness of the cap's fabric.



Figure 36 - Cap Ring

To do so, loosen the screw on the bottom right of the cap ring using a Phillip screwdriver. Tighten the screw once you have reached the desired position for the band.

How to remove the cap driver

1. Using the 4 mm Allen wrench included in your toolkit, loosen the hex screws that connect the cap driver to the pantograph.
2. To remove the cap driver, carefully pull the cap driver toward you using both hands. Keep in mind: It's not necessary to completely remove the screws. It should be able to slide off easily if you have loosened both hex screws.
3. Repeat this process with the remaining heads.

How to install the cap driver

1. First, select the cap hoop on your control panel. You will find the preset hoop function under the Design Settings menu. Once you have selected the preset cap hoop, the pantograph will move forward.
2. If you haven't done so already, make sure the flat support bracket is removed. To remove the bracket, loosen the hex screws that attach the bracket to the pantograph rail.

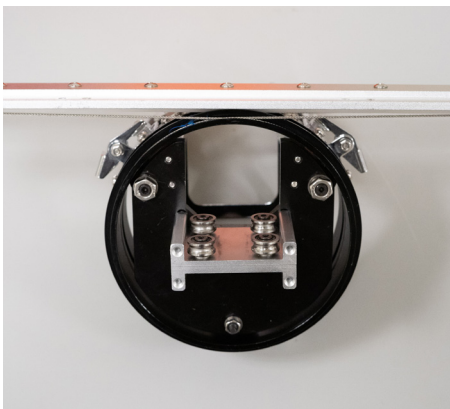

Figure 37

3. Insert the cap driver on the machine, making sure the sewing arm goes through the opening in the back of the cap driver. Each cap driver and cap ring is numbered. Use the cap driver labeled "1" for head 1. Use the cap driver labeled "2" for head 2, and so on.

4. The cap driver is equipped with four small wheels that slide onto the rail underneath the sewing arm of the machine. Position the cap driver in line with the railing, making sure all the wheels are aligned. **See Figure 37.**

5. Slide the cap driver in through the machine's sewing until it reaches the pantograph.
6. Line up the slots on each end of the cap driver bracket with the hex screws and the slots on the inside of the cap driver bracket with the support pins on the pantograph rail.
7. Tighten the hex screws using the 4 mm Allen wrench to secure the cap driver to the pantograph.
8. Repeat this process on the remaining heads.

Flat hoops and brackets

Your Ricoma CHT2 Series embroidery machine includes a set of 10 hoops per head. There are five different sizes ranging from A to E. Hoop A is the smallest hoop and hoop E is the largest hoop. You will receive 8-24 of each hoop depending on the amount of heads your machine comes with. You will also receive one sash frame with your machine. For information on installing the sash frame, refer to the section on how to install the sash frame.

A general rule of thumb most embroiderers follow when selecting hoops is to use the smallest hoop that your design will fit in without hitting the frame. When you upload your design, you will be able to use



Figure 38

the preset hoop feature on the machine to make sure your design is within the frame.

Selecting the smallest hoop your design fits in creates the best hooping tension for your fabric, eliminating thread breaks, puckering and other machine embroidery issues. Whenever you are using a square or rectangular hoop, the only places you are really getting a grip on the fabric is in the corners. In contrast, round hoops have equal holding power all around the circle.

How to attach the flat frame bracket

In order to run flats on your machine, you will first need to connect the flat frame bracket onto the pantograph rail. This bracket will support your hoops when embroidering on flat garments such as polo shirts.



Figure 39

1. Locate the flat frame bracket that comes with your machine. When attaching the bracket to the pantograph rail, make the curved side of each bracket arm is facing the inside and the flat side is facing the outside. **See Figure 39.**

2. Slide the bracket onto the pantograph rail, lining up the slots on the ends of the bracket with the hex screws and the slots on the inside of the bracket with the support pins. **See Figure 40.**

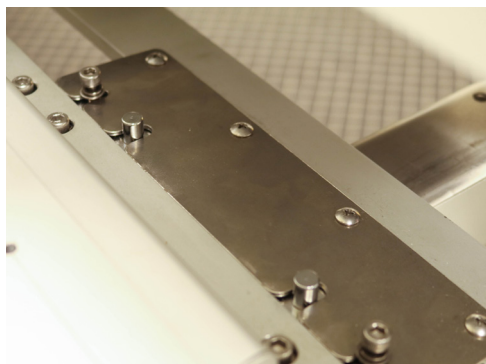

Figure 40

3. Secure the bracket to the pantograph rail of the machine using the 4 mm Allen wrench.

Note: The brackets are composed of two metal plates with a slot in between them. When you attach the brackets to the machine, make sure the pantograph rail is positioned in between the two metal plates and the screws are lined up with the slots.

How to remove the flat frame bracket

You will need to remove the flat frame bracket when using the extended table or when embroidering on caps. To remove the flat bracket, loosen the arms by rotating the screws counterclockwise with the 4 mm Allen wrench. Then, pull the arms straight out toward the front of the machine.

Note: Make sure the brackets are positioned underneath the washers. When you loosen the screws, the washers will automatically raise, so you can easily slide the bracket underneath the washer.

How to insert the hoop into the machine

The metal arms of the hoops are designed to slip under the clips on the hoop brackets. To correctly insert the hoop onto the brackets, make sure the open-ended slot (the U-shaped notch) is facing the machine. You should see the U shape on the top edge of the hoop, and it should always be on the right side. **See Figure 41.**

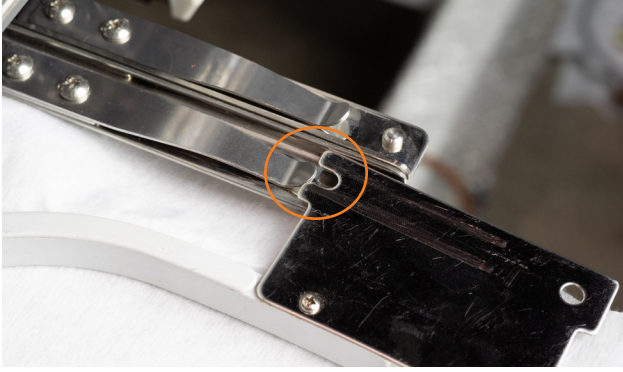

Figure 41

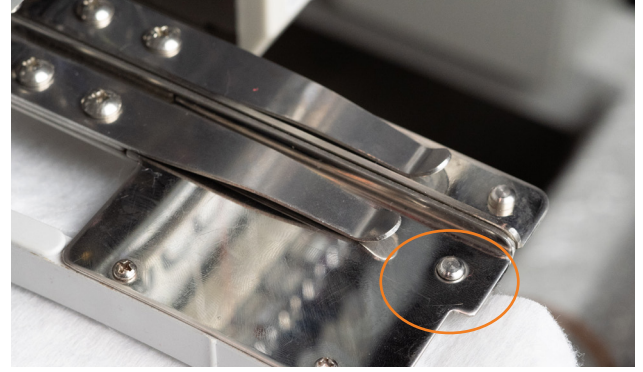

Figure 42

When inserted correctly and completely, the edge of the hoop slips under the recessed notch at the end of the clip. The notches in the hoop will be held securely under the prongs near the end of the clips. **See Figure 42.**

Note: When hooping, you must remember to orient the garment so that the leading edge of the hoop is the one with the U-shaped notch.

How to remove the hoop from the machine

To remove the hoop, lift the hoop arms to release the pressure on the notches. The hoop brackets will hold the hoops very tightly at first, but it will gradually become easier to lift the hoop from the bracket as you pull the hoop out.

EMBROIDERING WITH THE EXTENDED TABLE

How to install the extended table

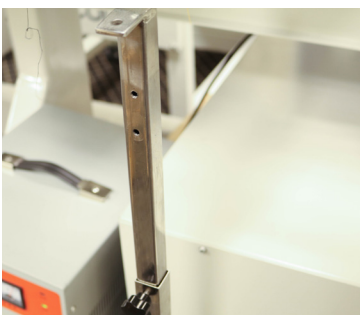

Figure 43

Your embroidery machine includes an extended table that can be used as a workspace or to support your sash frame during embroidery. Before installing the extended table, make sure your table support pegs are secured into place because your table will rest on the pegs.

1. Begin by lifting the table support pegs. To do so, you will need to loosen the hex screw on the bottom of the rod by rotating your 5 mm Allen wrench counterclockwise. **See Figure 43.**
2. After lifting the pegs, remove the black knobs to position the pegs to your liking.

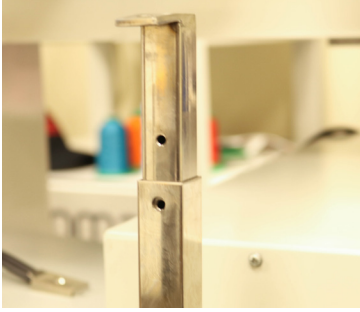

Figure 44



Figure 45



Figure 46



Figure 47

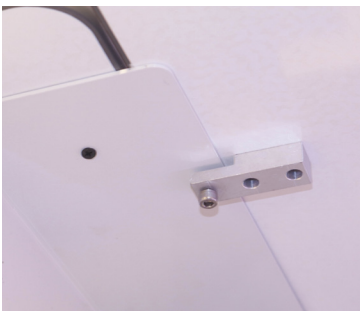

Figure 48

3. Line up the holes in the inner peg with the holes in the outer peg in order to re-insert the black knobs. **See Figure 44.**
4. Secure the positioning of the pegs by rotating the knobs clockwise. Note: You may position the pegs lower to use your table as a workbench. However, in order to use the sash frame, you will need to position the pegs at their highest point.
5. Loosen the hex screw on the middle metal bracket underneath the table in order to slide the table onto the machine's lip. **See Figure 45.**
6. Place the left table above the pegs, making sure the lip behind the sewing arm slides in between the metal clips underneath the table. Use the openings as a guide to help you see where to position the table. **See Figure 46.**
7. Underneath the center of the table, you will find a slot for the 5 mm Phillip screw included in your toolkit. Insert the screw into the slot and the pegs, and fasten the screw to attach the table to the pegs. **See Figure 47.**
8. Using your hand, fasten the hex screw on the top center metal clip underneath the table to keep the table stable. You can lock these in with your Allen wrench after you have placed all the tables on. **See Figure 48.**
9. Place all the remaining tables above the pegs, making sure the lip behind the sewing arm slides in between the metal clips underneath the tables.
10. Repeat steps 7 & 8 for all remaining tables.
11. Secure all screws tightly to keep the table stable during the embroidery process.

Attaching the sash frame

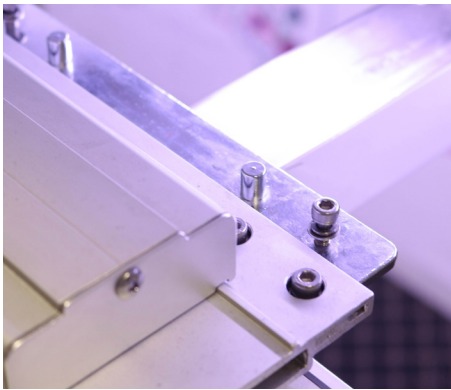

Figure 49

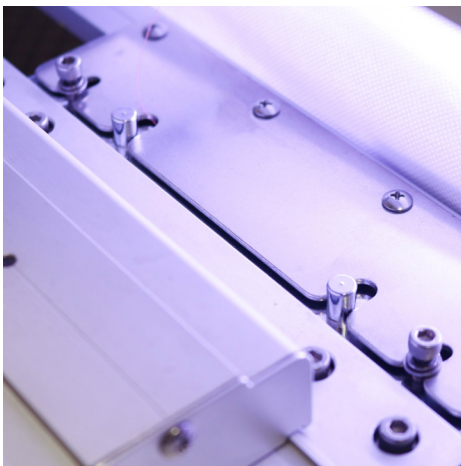

Figure 50

The sash frame is the largest hoop included with your machine. Before attaching the sash frame to the pantograph, make sure the extended table has already been installed and is positioned at its highest point. For instructions on attaching the extended table, please refer to the How to install the extended table section. Once the table is attached, place the sash frame on top.

1. Loosen the two hex screws located on the metal bracket attached to the pantograph rail. **See Figure 49.**
2. Slide the sash frame into the machine, lining up the slots on the outer end of the sash frame's bracket with the hex screws, and the slots on the inner end of the sash frame's bracket with the support pins. **See Figure 50.**
3. Tighten all the screws using the 4 mm Allen wrench.

HOOPING

Finding the center of your design for a left-chest logo



Figure 51

Before hooping your garment, you must determine the proper placement of the design. To determine where to place the design, you must first find the center of the design. Keep in mind: The center will vary on the size of the garment you are embroidering and the size of the design you are stitching. Design placement recommendations for a typical left-chest logo are as follows:

- **Women's:** Mark a point about 5 to 7 inches down from the area where the shoulder seam and the collar meet. Mark another point about 4 to 5 inches from the center of the shirt. Place the center of the design at the intersection of the points.

• **Men's:** Mark a point about 7 to 9 inches down from the area where the shoulder seam and the collar meet. Mark another point about 4 to 5 inches from the center of the shirt. Place the center of the design at the intersection of the points.

Tips to keep in mind:

The design should always be slightly closer to the center placket (front center) than to the armhole seam.

- If desired, mark the center with a water-soluble pen, a piece of masking tape or painters tape.
- Insert the bottom hoop ring either through the bottom of the shirt or through the opening in the neck area. Many embroiderers insert the hoop through the bottom of the shirt to avoid unbuttoning the collar. This also reduces the chance of soiling the collar area during embroidery.
- Regardless of whether you prefer to load the shirt through the neck opening or bottom opening, you must remember to orient the hoop so that the U-shaped notch is the leading edge of the hoop. When hooping the garment, make sure the hoop is facing in the same direction as it will enter the machine.

HOOPING A POLO OR GOLF SHIRT



Figure 52 - correct



Figure 53 - incorrect

1. Place the bottom ring inside the shirt. Make sure the adjusting screw on the bottom ring is facing the bottom opening of the shirt. That way, you can quickly adjust the screw in the event that the hoop is either too tight or too loose.
2. Place the backing over the bottom ring, making sure all areas of the hoop are completely covered.
3. Place the top ring over the front of the garment, and align it with the bottom hoop. Push down on the hoop to insert the top ring into the bottom ring.
4. After inserting the top ring into the bottom ring, verify you've hooped the fabric correctly. Make sure the fabric is smooth and tight, but not stretched. Try to lift the fabric from the stabilizer. If it's difficult to lift, your fabric should be hooped

correctly.

5. Last, turn the garment over to confirm that the stabilizer covers all sides of the hoop. If it does not, re-hoop the garment.

HOOPING A HOODIE OR JACKET



Figure 54



Figure 55



Figure 56

Like all other garments, hooping a hoodie or jacket requires finding the proper placement of the design. A good starting point is about 8 inches below the center shoulder seam. However, the placement of the design will vary based on the size of the design and the size of the garment.

1. Unzip the zipper and place the bottom ring inside the jacket as shown in **Figure 54**.
2. Position the stabilizer over the bottom ring, making sure it completely covers all sides of the hoop. **See Figure 55**.
3. Place the top ring over the front of the garment, and align it with the bottom hoop. Push down on the hoop to insert the top ring into the bottom ring.
4. After inserting the top ring into the bottom ring, verify you've hooped the fabric correctly. Make sure the fabric is smooth and tight, but not stretched. Try to lift the fabric from the stabilizer. If it's difficult to lift, your fabric should be hooped correctly.
5. Once hooped, the stabilizer should cover all areas of the hoop. If it does not, re-hoop the garment. **See Figure 56**.

Hooping the front or sides of a cap



Figure 57

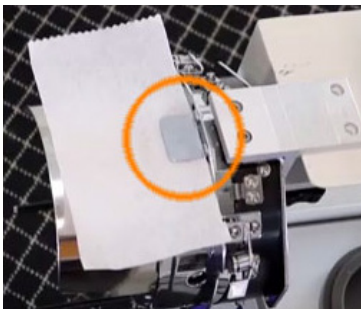

Figure 58

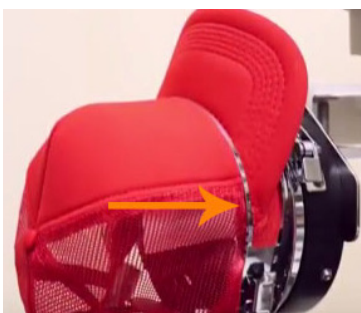

Figure 59



Figure 60

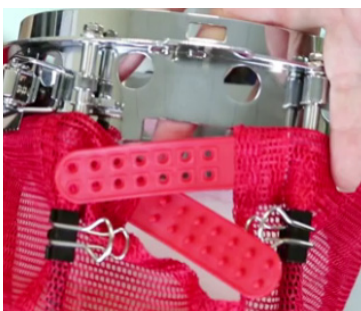

Figure 61

1. First, make sure the cap ring is connected to the cap station. To do so, connect the open metal notch on the cap ring to the center tab on the cap station. Grab the cap ring from the back, and push it forward. Make sure the cap ring snaps into all three of the spring locks on the cap station.
2. Once the cap ring is connected to the cap station, unfasten the metal band and let it rest to the left side of the cap ring.
3. To prepare the cap for embroidery, make sure the bill of the cap is as flat as possible. Unfasten the straps on the back of the hat if any.
4. Pull back the sweatband located below the bill of the cap. Make sure the entire sweatband is pulled back from seam to seam. **See Figure 57.**
5. Place the backing under the bill stop (the metal tab on the top of the ring). **See Figure 58.**
6. Slide the hat onto the cap frame, keeping the sweatband under the bill stop. Make sure the cap is pushed up tightly against the bill stop, not on top of it.
7. Position the flexible metal strap over the cap's bill, keeping the serrated edge of the band as close to the bill as possible. **See Figure 59.**
8. Connect the clasp to the cap ring latch and snap it into place. **See Figure 60.** Pull the sides of the hat to make sure it is tight and not wrinkled.
9. Pick up the excess fabric on the back of the hat, and secure it using the provided metal clips. Clip the fabric to the metal bars inside the cap ring to keep the cap tight. Make sure the handle of the clips face the center of the cap and toward each other. **See Figure 61.**

Hooping the back of the cap using a round hoop

1. Take hoop A or B.
2. Find a surface that is the width of the bottom ring of the hoop you have chosen. The corner of a table would work.
3. Place the bottom ring on that surface.
4. Place your backing on top of the bottom ring. It would be helpful to use adhesive spray on the backing or adhesive backing.
5. Place the cap on top of the bottom ring and backing.
6. Smooth out the material, eliminating any wrinkles.
7. Place the top ring over the fabric, and align it with the bottom ring.
8. Join the top and bottom ring, as you would with flats.

CONTROL PANEL OVERVIEW

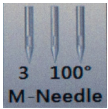

MANUAL COLOR CHANGE

This key displays the current needle setting and is used to command your machine to move to a certain needle.



START-UP

This key is used to set the color-change mode. You can set the mode to automatic, semi-automatic or manual.



EMB MODE MENU

This key is used to fast-forward or rewind through your embroidery designs.



PARAMETERS

Used to adjust the machine parameters. We do not recommend changing any settings without the help of a certified Ricoma technician.



DESIGN

This key is used to select, display, delete, copy, divide, combine, edit and group designs in the machine's memory.

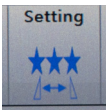

DESIGN SETTINGS

This key is used to customize design settings like the design direction, rotation angle and frame type.

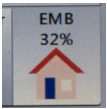

EMBROIDERY PROGRESS

This key displays the progress of the embroidery job. At 0%, the embroidery has not yet begun. At 100%, the embroidery is complete.



COLOR SEQUENCE MENU

Used to select color sequence settings. The left side displays the current working needle and any additional settings, and right side displays the upcoming working needle and its additional settings.

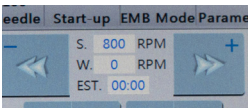

SPEED

These keys are used to increase or decrease the speed of the embroidery in stitches per minute (spm).

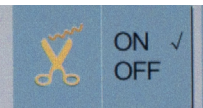

TRIMMING

This key is used to command the machine to trim during embroidery.

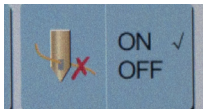

THREAD BREAK DETECTION

This key is used to detect thread breaks during embroidery.

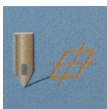

START POINT SETUP

This key is used to save the start point, restore the start point or pick up where you left off.



PRODUCTION STATISTICS

This key is used to look at production stats that will help guide you in increasing efficiency such as how many garments you've embroidered, how many thread breaks you've gotten, and the total stitches you've embroidered.



TRACING MENU

Used to trace your design to avoid hitting the hoops and make sure the design is centered.



RETURN TO ORIGIN

This is used to restart the design and return to the design origin back to its original placement when you need to embroider another one of the same design.



RETURN TO EMBROIDERY STOP POINT

It is used to return to the embroidery stop point if the frame was moved during embroidery.



EMBROIDERY STATUS

When this icon appears unlocked, embroidery status is removed. When removed, you are able to import designs and set different settings. When locked, the machine is ready to embroider.



MANUAL TRIMMING

Used to trim the thread on the selected needle.



100 DEGREE

Used to return the machine to 100 degrees during a main axis (motor fault) error.



START

Used to start embroidery and forward through designs during stitch floating mode.



STOP

Used to stop embroidery and rewind through designs during stitch floating mode.

Full embroidery process from start to finish

To start an embroidery job, you must follow these steps in order. In the following sections, you'll learn how to perform these functions on your control panel.

1. Remove your embroidery status. See page
2. Use the Design menu to upload your design and select it from the list. See page
3. Select a hoop from the preset hoops in the Design Settings menu. See page
4. If necessary, make anything changes to the design settings such as rotation angle under the Design Settings menu. See page
5. Select the color sequence of your design under the Color Sequence Settings menu. See page
6. Position your design using the directional arrows on the panel. See page
7. Trace your design to confirm it's in the correct place. See page
8. Set your desired speed. See page
9. Press start! See page

How to change your embroidery status

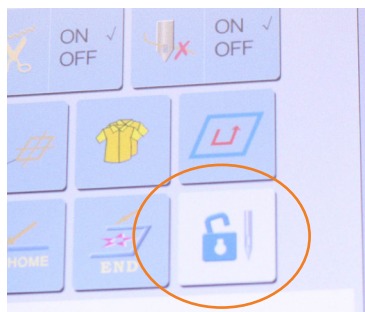

Figure 62

Your embroidery machine has two embroidery statuses: preparation status (setup mode) and working status (embroidery mode). To switch from embroidery mode to setup mode, tap the “Embroidery Status” key to unlock it. This will allow you to access basic panel functions, such as importing a design.

When you are ready to stitch, you will need to enter working status, which will display a locked icon on the embroidery status key.

Design menu

Under this menu, you will be able to perform certain design functions such as:

- Viewing details on your design
- Uploading a design into your machine’s memory
- Selecting a design for embroidery
- Deleting designs from your machine’s memory
- Combining two separate designs
- Dividing a single design
- Adding personalization to your designs

HOW TO UPLOAD A DESIGN

Your Ricoma embroidery machine reads DST files, the most common of all embroidery file types. If your embroidery file is in another file type, you will need to change the file type by using the software that comes with your machine. In order to run an embroidery job, you must first import a DST file into the machine using a USB. Keep in mind: You can’t embroider straight from the USB, so follow these steps to upload the design directly to the machine’s memory.

1. Once you have your DST file saved onto your USB, insert the USB drive into the USB port on the right side of the panel.
2. After inserting the USB, make sure the embroidery status is unlocked. You can do so by selecting the Embroidery Status key (lock icon) located on your control panel’s main menu. If the Embroidery Status icon appears to be locked, the machine is on “embroidery mode.” If the icon appears unlocked, the machine is on “setup mode.” Ensure that your machine is on setup mode before moving on.
3. Press the Design key to enter the USB/embroidery machine’s memory interface. Select the USB icon. (The USB icon should be highlighted blue to indicate that it is selected.) **See Figure 63.**

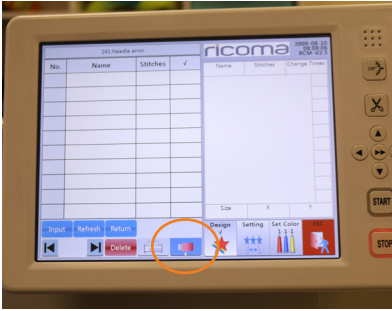

Figure 63

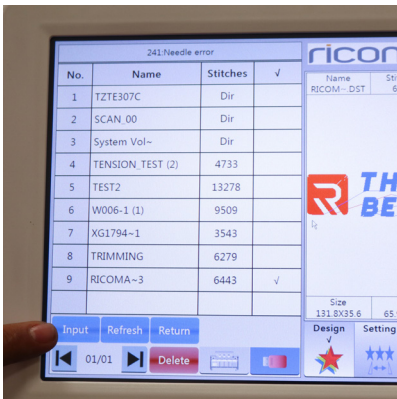

Figure 64

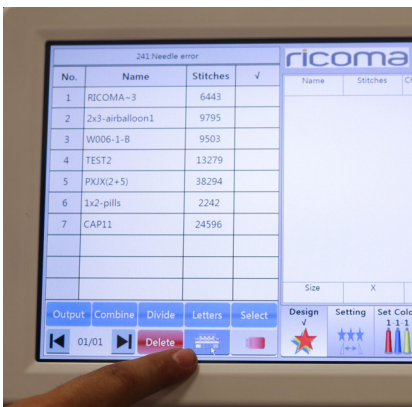

Figure 65

4. Your machine will now display a list of all the files in your USB's memory.
5. Select the file you wish to input, and select the "Input" key on the screen. **See Figure 64.**
6. Then, click on the machine's memory icon located to the left of the USB's memory icon. **See Figure 65.**
7. The design you just recently saved should now appear first on the list of the machine's saved designs.
8. Next, click on the design you wish to embroider, and click the "select" key.
9. The machine will ask if you would like to embroider the current design. Select "yes."
10. The design should now appear on the main menu of the machine's panel. You're now ready to center and trace your design for embroidery!

HOW TO EXPORT A DESIGN

In some cases, you may want to export a design that you have saved on your machine's memory into your USB in case you no longer have it saved on your computer or have switched computers. Follow these steps to export your design.

1. With embroidery mode unlocked, select the Design key to enter the USB/embroidery machine's memory interface.
2. Select the embroidery machine's memory, making sure the embroidery machine icon is highlighted blue.
3. Select the design you wish to export from the list of designs in the machine's memory.

4. Then, select the “output” key to transfer the file to your USB’s memory.

HOW TO DELETE A DESIGN FROM YOUR MACHINE’S MEMORY

The machine’s memory holds 50 million stitches. To clear space, delete the designs you’ll no longer need. Follow these quick steps to delete a design from your machine’s memory.

1. With embroidery mode unlocked, select the Design key to enter the USB/embroidery machine’s memory interface.
2. Select the embroidery machine’s memory, making sure the embroidery machine icon is highlighted blue.
3. Select the design you wish to delete from the list of designs in the machine’s memory.
4. Then, select the “delete” key to remove the file from your machine’s memory.

HOW TO COMBINE AND DIVIDE DESIGNS

In some cases, you may want to combine two designs or divide a design into separate designs. Follow these steps to combine two designs in a single run.



Figure 66

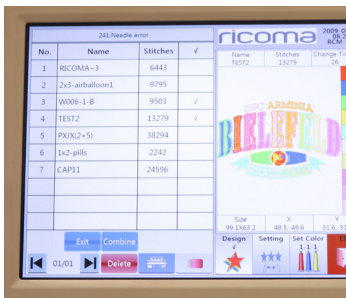

Figure 67

1. With embroidery mode unlocked, select the Design key to enter the USB/embroidery machine’s memory interface.
2. Select the embroidery machine’s memory, making sure the embroidery machine icon is highlighted blue.
3. Select the “Combine” option along the bottom row of keys. **See Figure 66.**
4. Select the designs you wish to combine. Once selected, a check mark will appear next to the title of the design to verify you have that design selected. **See Figure 67.**
5. You can now select the distance between the designs in order to space them out. Input a value into the X-interval and Y-interval option in order to space them out. **See Figure 68.**

Note: The value will depend on your design and how much space you want between the design. We recommend starting at 50 and increasing in increments of 10 until you find the perfect spacing for your designs.

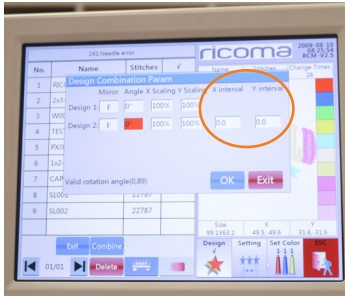

Figure 68

Follow these steps to divide your design into separate designs.

1. With embroidery mode unlocked, select the Design key to enter the USB/embroidery machine's memory interface.
2. Select the embroidery machine's memory, making sure the embroidery machine icon is highlighted blue.
3. Select the design you wish to delete from the list of designs in the machine's memory.
4. Select the "Divide" option along the bottom row of keys. **See Figure 69.**
5. A menu will appear. Under the "dividing stitches" option, input the number of stitches you wish to be the cut-off point to divide the design. **See Figure 70.**
6. Press "Enter," then press "OK."
7. You will now see your divided design in the menu.

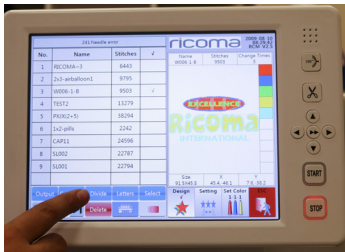

Figure 69

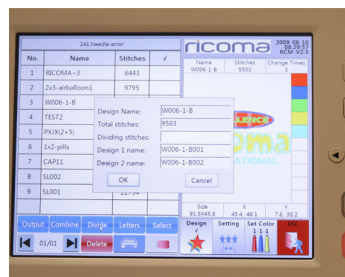

Figure 70

ON-BOARD LETTERING

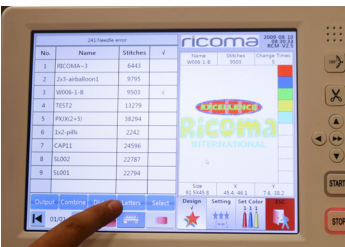

Figure 71

You can create personalization directly on your machine using the machine's on-board lettering feature. Follow these steps to add a name or title to a design.

1. With embroidery mode unlocked, select the Design key to enter the USB/embroidery machine's memory interface.
2. Select the embroidery machine's memory, making sure the embroidery machine icon is highlighted blue.
3. Select the "Letters" option along the bottom row of keys. This will open the on-board lettering interface. **See Figure 71.**
4. In the lettering menu, click on the "Input Characters" option and type in the word you wish to embroider. **See Figure 72.**
5. The second option in the on-board lettering interface reads "Arrangement." Select this option and choose from the list to arrange your letters horizontally or vertically. **See Figure 73.**

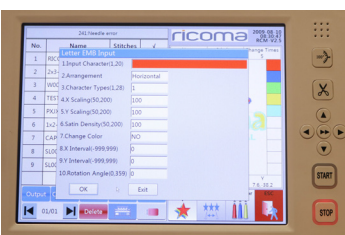

Figure 72



Figure 73

Note: For best results, the density and X and Y scaling are set at 100 as the standard. You can adjust the density of the lettering under the “Satin Density” option. The “X Scaling” and “Y scaling” option should remain at 100 for the best results. If you do wish to resize the design, then make sure you change both the X and Y scaling to the same number.

Design settings menu

You may open the Design Settings menu during preparation status. Under this menu, you will be able to command the machine to perform the following functions:

- Select the preset hoops on your machine
- Resize your design
- Rotate your design
- Select a customized angle for your design
- Repeat a design
- Adjust the density of your design

SELECTING PRESET HOOPS

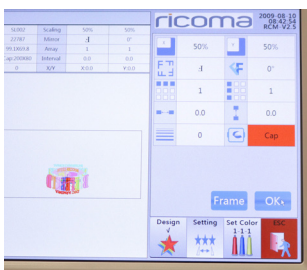

Figure 74

Before embroidering, it is important to first select the preset hoop on your control panel to match the hoop you’re embroidering with.

You will select the preset hoop that corresponds with the hoop you’re using under the design settings menu.

To do so, follow these simple steps.

1. Select the function represented by an image of a cap inside a frame. **See Figure 74.**
2. A list of all the preset hoops on your machine will appear.
3. Select the hoop you will be using. **See Figure 75.**
4. Your machine will now position itself to match the preset hoop you’ve selected.



Figure 75

Note: If a hoop is not selected, the system will continue to use the currently selected hoop.

Note: Hoop G will be used for embroidery on your sash frame. The cap option will be used for cap embroidery, and the “Other” option will be used for hoops that are not preset on your machine, such as the 8-in-1 hoop, or any other specialty hoop size.

RESIZING A DESIGN

The X & Y axes are represented by the number 100. This means, the logo will be embroidered at 100 percent. These measurements can range from 50 percent to 200 percent. You can increase or decrease the logo size by changing the X & Y measurements.

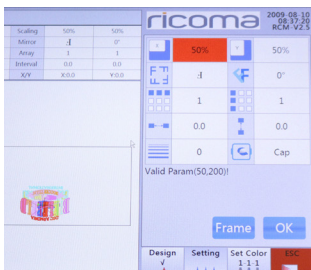

Figure 76

To do so, click on the “X” icon and input the new value you’d like to resize your design to.

Then, click on the “Y” icon and input the same value you input into the X axis.

See Figure 76.

Note: If you change the measurements of either axis, you will need to change the measurements of the opposite axis by the same amount to avoid distorting the logo.

Tip: When making these changes, keep in mind the machine will not increase or decrease the number of stitches on your design. A big difference in the percentage (%) may distort the embroidery. We recommend adjusting this setting to no more than 115% and no less than 85%.

HOW TO ROTATE A DESIGN

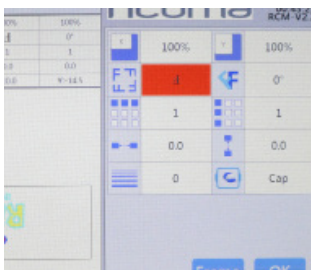

Figure 77

The rotate designs function allows the user to rotate the design in eight different directions.

To do so, select the rotate designs key represented by the F icon on your design settings menu. **See Figure 77.**

When you select this key, a variety of options will appear. **See Figure 78.**

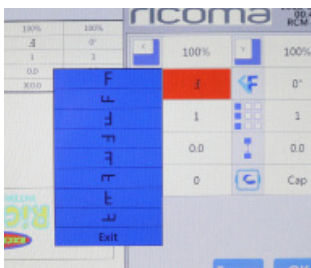

Figure 78

Select the desired position and press OK. The design will then appear on the screen with the changes you’ve made.

HOW TO ADJUST THE ROTATION ANGLE OF YOUR DESIGN



Figure 79

After you’ve rotated your design to a desired setting, you may also customize the rotation angle anywhere from 0 to 89°. To do so, select the icon with one ‘F’ and one slanted ‘F’ to add a specific angle to your design. **See Figure 79.**

Once you select this option, a numbered keypad will appear. Select the desired degrees in which you would like to position your design, and press “ENTER.”

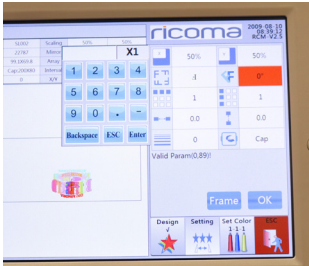

Figure 80

See Figure 80.

Now, press “OK.” The logo on your screen should now appear in the customized angle you selected.

HOW TO REPEAT DESIGN AND SELECT THE SPACE BETWEEN REPEATED DESIGNS

Your machine is capable of repeating the same design in one job. Embroiderers use this method to save time when running projects such as multiple patches. To do so, you will need to use the largest hoop possible, and repeat the logo as many times as it fits in your hoop area. To begin the process, you will have to choose whether you want to repeat your designs vertically or horizontally.

To stitch the design horizontally, select the third and fourth icon on the first column of your design settings menu. **See Figure 81.**

To stitch the design vertically, select the third and fourth icon on the second column of your design settings menu. **See Figure 82.**



Figure 81

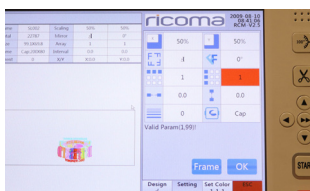

Figure 82



Figure 83

1. Select the third icon in either the first or second column depending on whether you want to stitch vertically or horizontally.
2. Input the number of logos you would like to repeat, and press “Enter.”
3. When repeating a design, you will need to select the space in between each of the designs by choosing the fourth icon on either the first or second column depending on whether you are repeating the design horizontally or vertically.
4. Next, input the amount of space you wish to place between your designs. These values will be represented in millimeters (“mm”). Once you’ve input the measurement, press “Enter,” and then “OK.” **See Figure 83.**
5. Your repeated designs will now appear on the screen.

ADJUSTING THE DENSITY OF THE DESIGN

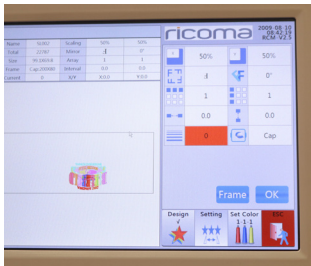

Figure 84

On the bottom left corner, you will find the density selection, which allows you to increase or decrease the density of your design. If you would like to increase the density, tap the area where the number appears and input the desired density value. After inputting the value, press “Enter,” and then “OK.” See Figure 84.

Color sequence settings

You can select the colors you are going to use for your embroidery project under the color sequence settings menu. In this menu, you can also offset your frame during a color stop for applique embroidery and slow down the speed of the machine during color certain color stops.

HOW TO SELECT A COLOR SEQUENCE

The menu will display the number of the needles you have selected for the embroidery job on the left side. On the right side of the screen, you select the numbers of the needles you wish to use. See Figure 85.



Figure 85

The number in the left box highlighted in light blue represents the color stop for the needle. The number in the white box represents the needle you have selected for that color stop.

The “repeat” function is used if you want to use the same color throughout the entire design. Instead of inputting the same color in each color stop box, you can just input the first needle and select “repeat.” The machine will then repeat the same color for all color stops.

HOW TO SLOW DOWN THE SPEED DURING ONE COLOR STOP

The “Speed Down” key allows you to slow down the speed during a certain color stop. This is helpful during color stops that have smaller detail, and thus require slower stitching speeds. Follow these steps to do so.

1. Open the color sequence settings menu.
2. Select the “Speed down” key.
3. Select the needle bar which you would like to slow down.
4. Input the speed which you would like the machine to run during that color stop. **See Figure 86.**

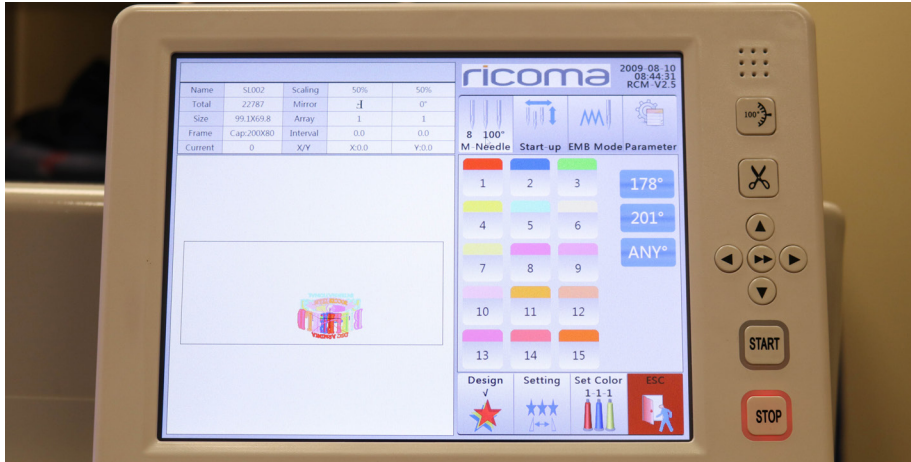

Figure 86

HOW TO OFFSET THE FRAME FOR APPLIQUE EMBROIDERY

Offsetting the frame during the applique process allows you to easily place your applique fabric during embroidery. Follow these steps to offset the frame before a certain color stop begins to stitch.

1. Open the color sequence settings menu.
2. Select the “Frame Out” key.
3. Select the needle bar which you would like for the frame to offset. **See Figure 87.**



Figure 87

Design tracing



Before running a design, it is a good idea to trace your design. This step will ensure the needle will not interfere with the hoop during embroidery and will also help you confirm the placement of your design. While tracing, your machine will move to needle #1. Follow along needle #1 to see where your design will be embroidered. There are two types of tracing: standard tracing and contour tracing.

Standard tracing will trace in a rectangular shape around the perimeters of your design, while contour tracing will give you a more precise trace along the edges of the design. Follow these simple steps to trace and contour trace.

To conduct any type of trace, first click on the tracing menu.

To perform a standard trace, hit the key that reads “Move frame along design range.” Then, click “yes,” and the machine will trace along the perimeters of your design.

To perform a contour trace, hit the key that reads “EMB design quadrature range.” Then, click “yes.” Last, hit “start” to begin the contour trace.

How to adjust embroidery speed

Press the plus and minus key to slow or accelerate the current speed. The section in the middle will display the speed your machine is running at. The top number is the speed you have selected to run your machine at, and the bottom number is the actual speed the machine is running at.

The third number that reads “EST” is the estimated embroidery time. **See Figure 88.**

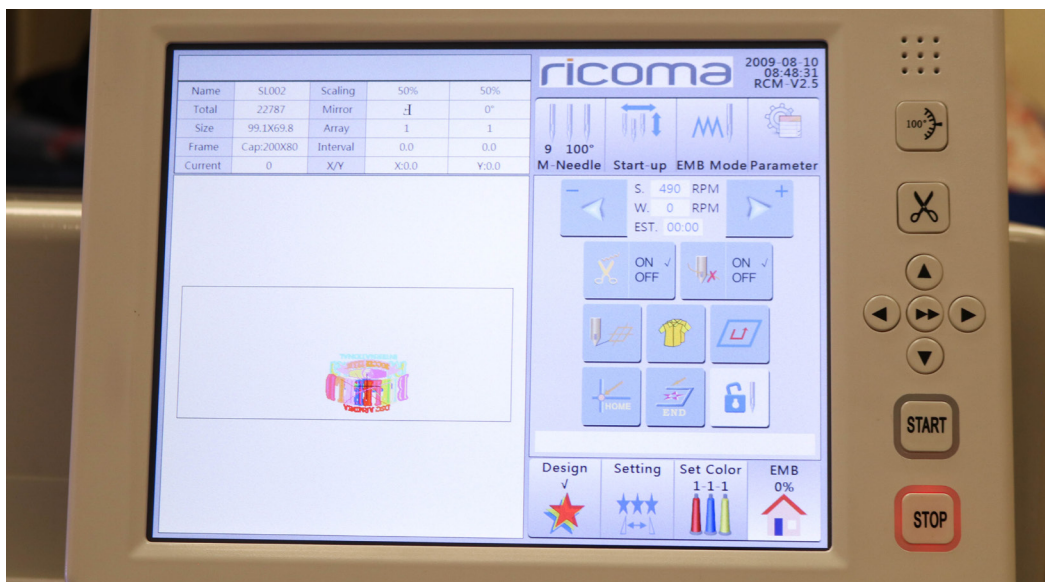

Figure 88

EMB mode menu

The EMB mode menu allows you to set a speed in which to “float” through your design in order to fast forward or rewind through your design without stitching. When you get a thread break, you should rewind your design a few stitches back to make sure you didn’t skip any stitches.

HOW TO FAST FORWARD AND REWIND YOUR DESIGNS

You can rewind through your stitches using the stop button on your panel and in between the machine’s heads. Refer to the section on how to rewind your design.

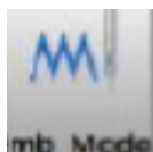

Figure 89

However, in order to fast-forward through your stitches, you will need to open up the EMB mode menu, select a speed in which to float through, and then press start.

Your EMB mode key will display the status of the embroidery. While your machine is embroidering (in working status), you will see the key with the needle and the zig zag line.

See Figure 89.

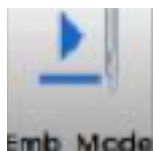

Figure 90

When your machine is forwarding or rewinding through your design in a low speed, the key will display one triangle. **See Figure 90.**

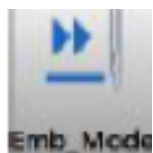

Figure 91

When your machine is forwarding or rewinding through your design in a high speed, the key will display two triangles. **See Figure 91.**

To switch between low and high speed floating, simply click on the corresponding key to go into low-speed or high-speed floating. Then, press stop for rewinding. And press start for fast-forwarding.

After forwarding or rewinding your design, make sure to tap on the working status icon to return the machine to embroidery mode.



Figure 92

In this menu, you can also forward or rewind through color stops or through a specific stitch count.

To forward or rewind through color stops, click on the forward color and backward color key until you’ve reached the area where you wish to begin stitching again.

To rewind or forward through a specific amount of stitches, input the value you wish to forward or rewind, using the arrow keys. Then, click on forward stitches to forward and backward stitches to rewind. **See Figure 92.**

Start-up menu/Color change mode



The embroidery machine's color change mode refers to the mode in which the needle changes from one color to the next. Most of the time, you will want your embroidery machine to be on fully automatic mode. This will command the machine to embroider the design the entire way through, without stopping between each color stop.

However, in some instances, you may want to change your color change mode from automatic to semi-automatic or manual. For instance, you may need your machine to stop in the middle of a design so you can place an applique fabric. If that's the case, you should set your machine to automatic/manual to stop the machine between each color stop.



Figure 93

When color change mode is on auto and startup mode is on auto, the machine will automatically switch needles and start again after each color stop. **See Figure 93.**



Figure 94

When color change mode is on auto and startup mode is on manual, the machine will stop after each color stop, and you will need to hit start again for it to continue stitching in the next color stop. **See Figure 94.**



Figure 95

When color change mode is on manual and startup mode is on manual, you will have to manually select your needle and then press start after every color stop. **See Figure 95.**

Manual color change/needle display

The needle display icon is located on the top left corner of the main menu and is also the manual color change key.



Figure 96

This icon displays two important features on your machine. The large number on the left side represents the working needle, and the number on right side displays the degree the machine is aligned to. In order to operate, the machine must have a needle selected and be aligned to 100 degrees. Therefore, make sure the number on the right side appears as 100, and that the number on the left matches the number of the needle you have selected.

To move your machine head from one needle to another manually, select this key and choose the needle you wish to move your machine to. **See Figure 96.**

Trimming

The trimming button is used to trim the top and bobbin thread if you need to move to another needle or if you want to stop your machine during embroidery and remove your hoop.

Trimming is also useful when rethreading a needle because it automatically inserts the thread from the needle's eye into the presser foot. This helps speed up the threading process.

You can press the trimming button during embroidery mode or setup mode as long as the machine isn't running. Press the key in order to trim the top or bobbin thread and then press "Yes." The machine will now trim on the selected needle.

MAINTENANCE

Oiling/Lubrication

Some embroidery machine issues can be linked to the lack of routine care, therefore proper maintenance is essential to prolong the life and functionality of your machine. It is necessary to oil your machine to ensure it operates smoothly. Lubricate your machine with sewing machine oil, which can be found in most sewing and embroidery supply stores, and white lithium grease, which can be found in many hardware stores. Before using any other product, please ask a certified technician to confirm the product is safe for your machine.

EVERY FOUR HOURS:

1. Remove the bobbin case and apply two to three drops of sewing machine oil on the race of the rotary hook, where the two sections of the hook meet. **See Figure 97.**
2. Remove the bobbin case and clean the hook assembly area with a soft brush, air compressor with a moisture filter or approved canned compressed gas product, such as Dust Off. **See Figure 98.**

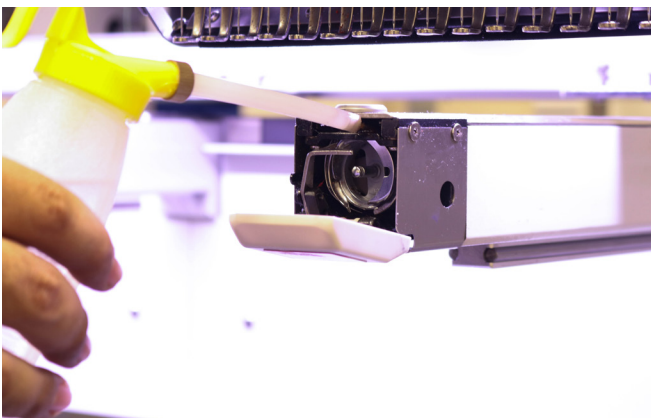

Figure 97

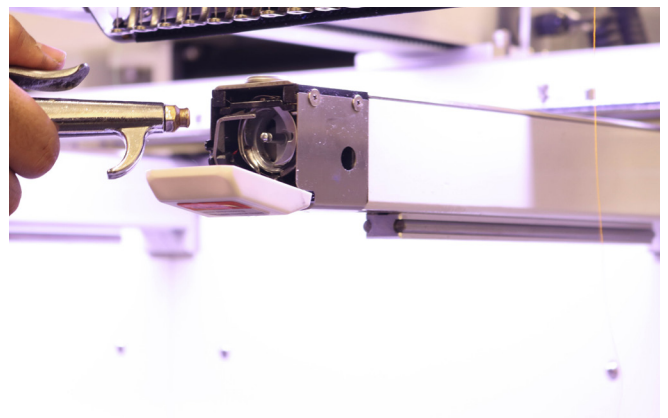

Figure 98

ONCE A WEEK:



Figure 99



Figure 100

1. Remove the needle plate located on top of the sewing arm. Once removed, clean around the trimmer knives with a soft brush, air compressor with a moisture filter or approved canned compressed gas product, such as Dust Off. **See Figure 99.**
2. Clean the lint from the slit on the bobbin case with the corner of a business card, or remove it with the bobbin thread itself like dental floss. Resist the temptation to blow the lint off the case—this deposits damaging saliva on your bobbin case. **See Figure 100.**

ONCE EVERY TWO WEEKS:



Figure 101



Figure 102

1. Apply two to three drops of sewing machine oil to the two openings on the front and back of the sewing arm. **See Figure 102.**
2. Remove the metal cover on each of the machine's heads and apply one to two drops of sewing machine oil on the lower needle bar of each needle. Note: The foam pads located behind the metal cover on the lower needle bars should soak up the oil. **See Figure 103.**

ONCE A YEAR:

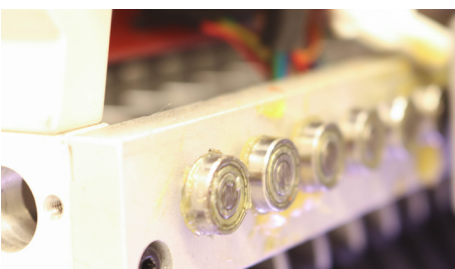

Figure 103

1. Apply white lithium grease to the bearings (metal rollers) on the back of the head. Move the machine's head from needle #1 to needle #15 to be able to see and apply the grease on all the metal rollers. **See Figure 103.**



Figure 104

2. Remove the cover on the pantograph using a Phillips screwdriver, and grease the black rail inside. **See Figure 104.**



Figure 105

3. Remove the metal plate that covers the gears located behind the sewing arm on the machine's table. Check the gears to see if they are greased. Apply grease if they are in need of grease. **See Figure 105.**

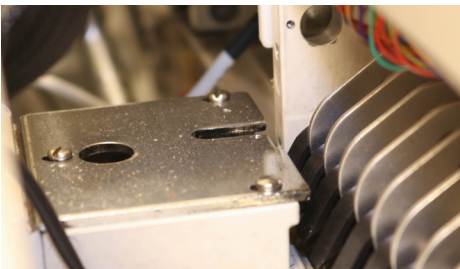

Figure 106

4. Apply five to six drops of oil to the cam reciprocator shaft on each head. **See Figure 106.**

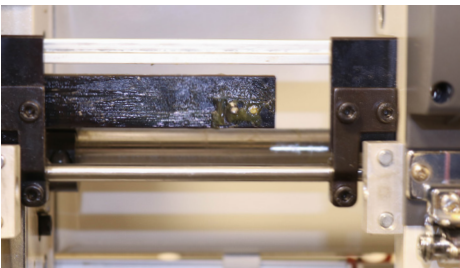

Figure 107

5. Remove the metal cover in between the two heads and apply white lithium grease on the cylindrical metal shaft that connects the machine's heads. **See Figure 107.**

Care of the bobbin case/rotary hook area

ONCE A DAY:

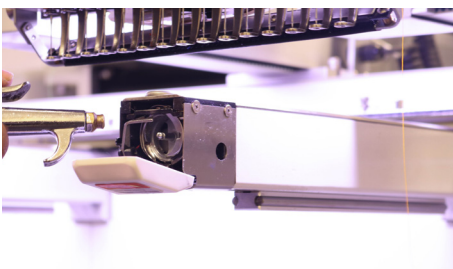

Figure 108

1. Once a day, remove the bobbin case and clean the hook assembly area with a soft brush, air compressor with a moisture filter or approved canned compressed gas product, such as Dust Off. **See Figure 108.**

ONCE A WEEK:



Figure 109



Figure 110

1. Once a week, remove the needle plate located on top of the sewing arm. Once removed, clean around the trimmer knives with a soft brush, air compressor with a moisture filter or approved canned compressed gas product, such as Dust Off. **See Figure 109.**
2. Once a week, clean the lint from the slit on the bobbin case with the corner of a business card, or remove it with the bobbin thread itself like dental floss. Resist the temptation to blow the lint off the case. This deposits damaging saliva on your bobbin case. **See Figure 110.**

COMMON ERRORS

Resolving a thread break

If a thread break occurs, the machine will stop automatically and you will receive a thread break alert on the embroidery status icon.

The thread will almost always break at the lower portion of the machine head. To correct this issue, thread the machine from where the thread break occurred all the way through the needle and down the presser foot. Then, rest the thread on the holding spring, leaving around 1 inch of thread hanging. If too much thread is left on the spring, it will not be pulled to the underside of the embroidery. If too little thread is left, the thread will not catch the bobbin.

After rethreading the machine, rewind your design. This step is essential because when a thread break occurs, the machine continues to advance forward momentarily. Therefore, the design should be backed up to ensure there is no gap or missed stitches on your design. To rewind, press the stop button, and let the machine back up approximately 10 to 12 stitches. Then, press the stop button again to command the machine to stop backing up further. Last, press the start button to resume sewing your design.

Replacing a needle

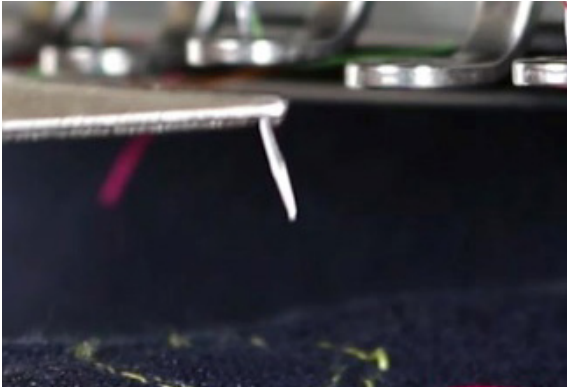

Figure 111

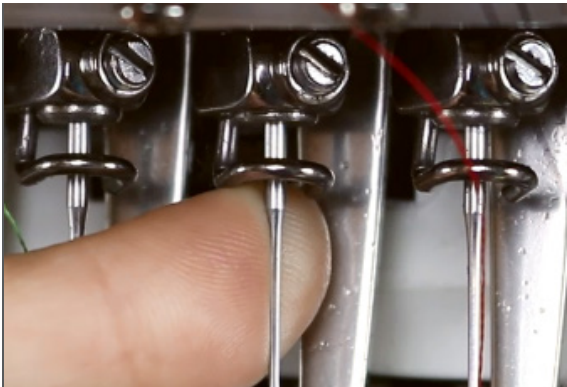

Figure 112

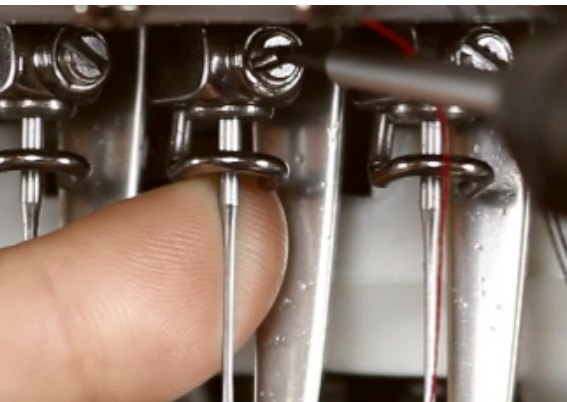

Figure 113

1. Begin by removing the broken needle from the garment. If it is not on the garment, check the bobbin area. **See Figure 111.**
2. Proceed by loosening the set screw above the needle with a straight slot screwdriver. Loosen only enough to be able to remove the needle.
3. Discard the spent needle in a childproof pill bottle or other sharp-safe container
4. Needles have a long groove on the front and a short half-moon-shaped section called the scarf on the rear. With the long groove facing the front of the machine, insert the new needle by placing the point through the presser foot, and then inserting the shank into the needle bar until it can be inserted no further. **See Figure 112.**
5. Verify that the long groove of the needle is still facing forward. Tighten the needle screw while holding the needle firmly to keep it from slipping down. **See Figure 113.**

Tip: To help you place the needle correctly, you may insert a wooden toothpick into the eye of the needle. Never place a metal object in the needle's eye, as it could scratch the eye of the needle, causing thread breaks.

Bobbin running out

If the bobbin thread runs out, the machine will stop automatically and a thread break alert will appear on the embroidery status icon.

To differentiate a thread break from the bobbin running out, take a look at the thread from the working needle. If it's still attached to the fabric, it means the bobbin ran out of thread or there is an issue with the bobbin thread. To correct this, remove the bobbin from the bobbin case. Replace it with a new bobbin, and then place the bobbin case back inside the rotary hook.

If necessary, back up your machine to ensure there are no missed stitches.

Emergency stop message

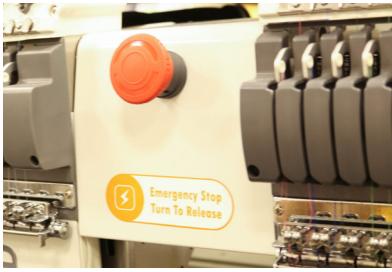

Figure 114

An emergency stop error occurs when the emergency stop switch has been pushed during shipping or under an emergency situation. If you receive an emergency stop error, you can easily get rid of it by rotating the emergency stop button clockwise, following the directional arrows on the button. **See Figure 114.**

Note: Be sure to not pull this switch up. It will pop out by itself once rotated. Pulling on it could damage the switch.

No needle error/color change error

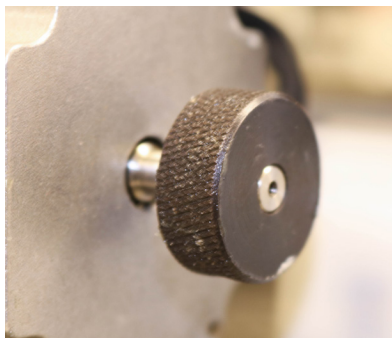

Figure 115

A no needle/color change error occurs when the machine cannot detect which needle is over the needle plate. This may happen because the machine head is positioned between two needle plates.

If you receive a needle error on your panel, you may see a question mark or a 0 appear on your needle icon where the needle number was once displayed. If so, clear the message and locate the color change motor shaft behind the control panel. Using an open-ended adjustable wrench, rotate the shaft slowly until the machine reaches a needle number. The color change box will light up on the needle the machine is aligned to. **See Figure 115.**

Motor fault error/Main axis error



Figure 116

The machine needs to be aligned to 100 degrees in order to operate properly. A main axis error means the main axis is not lined up to 100 degrees, which is the proper position for the machine to start and stop sewing.

This error can be caused if a needle hits the hoop, if you get a bird's nest, and other reasons. If you get this error, clear the message by pressing

OK.

To correct this error, you can use the 100 degree key on your panel, which automates the process of

aligning your machine to 100 degrees.

Then, make sure there is a working needle number displayed on the needle icon. If no needle is displayed, refer to the “No needle error” section.

Once you’ve made sure a working needle is selected, press the 100 degree button on your control panel once again. Most of the time, your machine’s main axis will align itself after this step, and you may continue operating your machine.

If you are still receiving an error message after performing this step, you will need to align it manually using the degree wheel on the left side of your machine. Note: You must turn off the machine before performing this step.

1. On the left side of your machine, you will find two small openings. On one, you will see the degree the machine is aligned to. On the other one, you’ll find a hex screw. **See Figure 116.**
2. Use the 5 mm Allen wrench to rotate the axis counterclockwise until the dial aligns to 100 degrees.
3. Turn the machine back on. When the panel shows the main menu screen, press the 100 degree button on your panel. At this point, the machine should be ready to embroider.

Hook timing

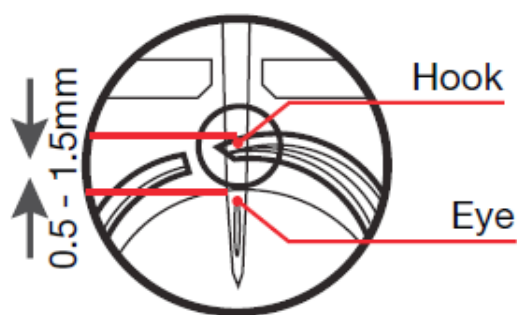

Figure 117

Hook timing refers to the synchronization of the rotary hook with the needle. Proper timing is critical for embroidery quality and to prevent issues. If the space between the needle and the hook point is out of range, the thread will not catch, causing thread breaks. If the space between the needle and hook point is too close, it will cause broken needles. **See Figure 117.**

You can set your rotary hook timing by rotating the main shaft of your machine to a specific degree and then adjusting the rotary hook at that particular degree. This is known as the “timing degree.” The CHT2’s timing degree is 201 degrees.

When timing is correct, the tip of the rotary hook should be directly lined up behind the needle’s scarf, and the proper space between the needle and the hook should be 0.1 mm to 0.3 mm. **See Figure 118.**

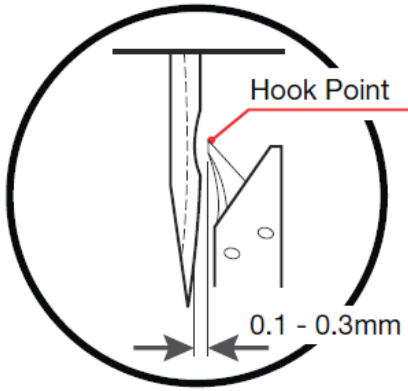

Figure 118

Note: If your timing is off, contact a certified Ricoma technician to walk you through the process.

TENSION

Tension

Proper thread tension is necessary for quality embroidery. Improper thread tension will cause a number of embroidery issues. For instance, tension that is too loose will cause threads to loop; and tension that is too tight may cause frequent thread breaks.

Tension will depend on the complexity of your design; the fabric, thread and backing you're using; and even hooping.



Figure 119

Before making any tension adjustments, make sure your machine is threaded correctly. Sometimes you may encounter tension issues simply because your machine is threaded improperly.

You can adjust the tension settings using the following:

- The spring lever
- The top tension knobs
- The bobbin case

If you've verified your machine is threaded correctly, start by adjusting the check spring lever. **See Figure 119.**

Please keep in mind: Before making any tension adjustments using other factors such as the bobbin case and the tension knobs, we recommend first adjusting the spring lever – as this is the quickest fix and small changes to the spring lever may regulate the tension on your design.

Adjusting the top tread tension: Spring lever

The spring lever controls the tension of all the needles, while the tension knobs control the tension of the working needle.

We recommend maintaining the spring lever directly in the center, at a 90-degree angle. When adjusting thread tension, position the ever one or two clicks either up or down from the center. The spring lever's placement will vary depending on your material and design.

- When sewing heavy materials, place the spring lever lower.
- When sewing lightweight materials, place the spring lever higher.

You should never place the spring lever neither all the way up nor all the way down, as either scenario may result in thread breaks. If the spring lever is positioned all the way up, all of your needles' threads

Adjusting the top tread tension: Tension knobs

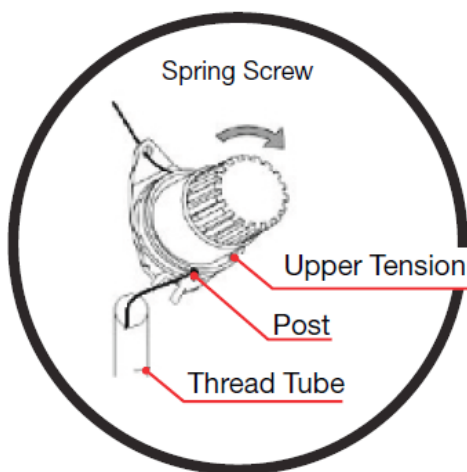

Figure 120

The top tension knobs allow users to quickly adjust tension settings on a single needle. Before you start adjusting your tension knobs, check the bobbin thread tension. The top tension knob is pictured in **Figure 120**.

If too much top thread is showing on the back of your design, tighten the top tension by rotating the knob clockwise. If too little top thread is showing on the back of your design, loosen the top tension by rotating the knob counterclockwise. We always recommend starting with small quarter turns either to loosen or tighten the tension. That way, you get a better idea of how each tension adjustment affects your design and get to know your machine better.

Tip: Experiment by making small adjustments until you feel comfortable with your design. Keep in mind: Every design is different and will require different tension settings.

The tension settings may vary by the thread's manufacturer. While most brands tend to be similar, the type of thread may have an effect on tension. For instance, polyester threads require nearly twice the amount of tension as rayon.

- Rayon thread tension should be from 100 to 120 grams.
- Polyester thread tension should be from 120 to 150 grams.

Depending on the type of thread you will use, you will need to adjust the tension knobs. For the best quality design, make the following tension adjustments when necessary.

- For metallic and polyester threads, rotate the tension knob one time counterclockwise.
- For light color rayon threads, rotate the tension knob one to two times counterclockwise.
- For white rayon thread, rotate the tension knob one time counterclockwise.
- For medium color rayon threads, rotate the tension knob one to two times counterclockwise.
- For dark color rayon threads, rotate the tension knob two to three times counterclockwise.
- For black rayon thread, rotate the tension knob three times counter clockwise.

TIP: When using a specialty thread, such as supertwist, lower the tension to prevent thread breaks.

TIP: If your tension is correct and you continue to experience thread breaks, make sure your needle is fresh. Old needles may produce burrs and lead to frequent thread breaks.

Adjusting the bobbin tension



Figure 121

Proper bobbin tension is essential for quality embroidery. If tension is incorrect, you may begin to experience frequent thread breaks.

You can fine-tune the bobbin tension by adjusting the large screw on your bobbin case.

Rotate the screw counterclockwise to loosen the tension, or rotate the screw clockwise to tighten the tension. **See Figure 121.**

When too much bobbin is showing on the back of your design, your bobbin tension is too loose. To resolve this, take your bobbin case and tighten it by rotating the large screw clockwise. This screw is labeled “Tension Adjusting Screw” in **Figure 122.**

When too much bobbin is showing, it also means your top tension is too tight and your top thread will appear smaller than your bobbin thread. You may need to slightly tighten the bobbin tension when stitching caps, thick materials or small details. **See Figure 123.**

When too little bobbin is showing on the back of your design, your bobbin is too tight. To resolve this, you will

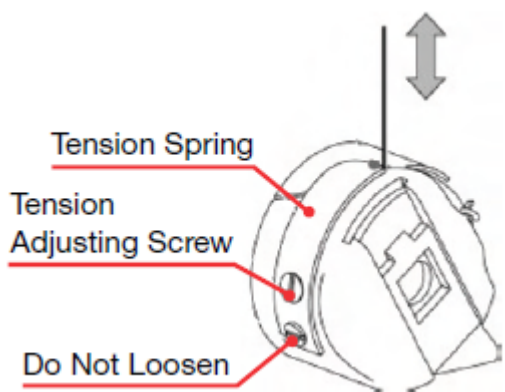

Figure 122

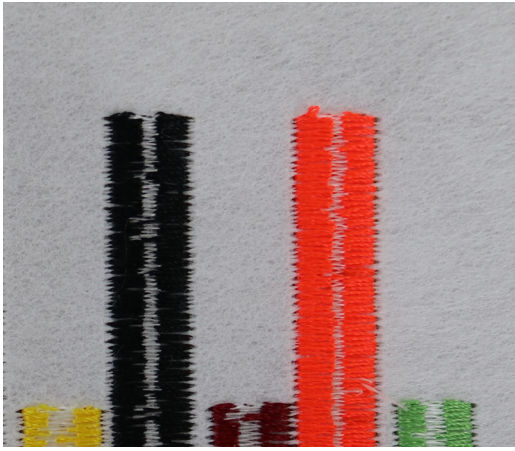

Figure 123

need to loosen the bobbin case by rotating the large screw counterclockwise.

Bobbin tension that is too tight may result in a narrow column, or even a single strand of bobbin thread down the center of the satin column stitched during the “I” test. This can cause the embroidery to unravel easily if the bobbin thread ever gets snagged. **See Figure 123.**

Even if the bobbin thread stays put underneath the embroidery, chances are, the columns will not have clean, crisp edges.

Erratic bobbin tension usually results from a catch in the bobbin case. For this reason, try pulling a few feet of bobbin thread to see if there is a point in the rotation of the bobbin in the case that is not smooth. This catch can be the result of an ill-fitting bobbin that has been overfilled or that has a manufacturing defect. If you suspect the bobbin is not rotating smoothly in the machine, check by placing the bobbin case face down on the machine table or a flat surface. Then, pull a few inches of thread out. If the bobbin isn’t spinning freely on the surface, the odds are that it isn’t spinning freely in the machine either. Retest the case with another bobbin.

If you are still experiencing bobbin tension issues after adjusting your bobbin thread, be sure that you are not using a damaged bobbin case, as this may cause undesirable results. Other factors can include improper top thread tensioning and damaged needles.

TIP: One tip-off that you need to adjust the bobbin case rather than the top tension knob is when similar symptoms are exhibited on all needle bars.

Other factors that affect tension

- The color of the thread is a factor that affects thread tension because the dye affects the texture of the thread. The texture of the thread affects how smoothly it slides through the machine and the needle.
- Another factor that contributes to tension is the weight of the thread. If you change the weight of the thread, you will need to adjust the tension.
- The speed of the machine may also affect tension. The slower the speed of the machine, the better quality designs it will stitch.
- Excess dust and lint along the thread path may also affect the thread tension.

THREAD BREAKS

Reasons why thread breaks occur

1. **Thick fabric:** If the fabric is too thick, needles will tend to bend slightly as thread passes through. This causes the thread to scrape against the needle plate, shredding the thread. To correct this issue, replace the existing needle with a larger needle.
2. **Hidden obstructions in the garment:** Obstructions such as bulky seams, inside pockets and hidden buttons, may cause thread breaks.
3. **Improper hooping:** Make sure the item is hooped properly. Loosely hooped fabric will bounce up and down during sewing.
4. **Excessive backing:** Excessive backing results in thread and needle breaks, as it applies greater friction to the thread and needle.
5. **Very high density designs:** Designs with high thread densities may cause needle deflection, which leads to thread shredding and thread breaks. Small designs with high densities pack too many stitches in a small area, causing thread breaks.
6. **Extremely short stitch lengths:** Short stitch lengths may cause thread to pile up in one area. Also called “nesting,” this issue may result in thread shredding and thread breaks. Try deleting short stitches or increasing the design by 5 to 10 percent.

Thread break prevention

1. **Proper thread care is necessary to prevent thread breaks.** We recommend storing thread in a dark, cool place. Old threads that have not been stored properly will cause thread breaks. Prolonged exposure to air, light, age and heat will cause threads to become brittle. If this occurs, replace the old thread and store the new thread in a dark, cool place.
2. **Do not use tape to tie off thread ends.** Tape leaves a sticky residue that causes friction and thread breaks.
3. **Check for burrs in the thread guides, needle eye, thread plate and hook.**
4. **Oiling your machine is essential to keep your machine running smoothly.** Keeping your rotary hook area clean with a hook cleaner is also vital, especially if you are using adhesive stabilizer or spray that leaves behind a residue that causes your thread to shred. Refer to the maintenance

section to learn how to properly care for your machine.

Thread break troubleshooting

There are a number of reasons why you may be experiencing recurring thread breaks. To ensure it is not a technical issue, follow these steps.

1. Check the thread path to make sure your machine is threaded correctly. It should be following the correct path detailed in the Threading section of this guide.
2. Make sure your thread tension is correct. Tight tension may lead to missed stitches, thread breaks, pulling, puckering and thread stress. Loose tension will cause thread to pile up and loop.
3. Inspect the needle position to determine if an actual thread break has occurred. Sometimes your machine may read a thread break, but the thread will still be attached to the fabric. If this is the case, check all the thread paths. Then, do a manual trim and check the bobbin supply. If the thread is broken, follow the correct thread path and rethread the needle.
4. Make sure the thread you're using is not defective. If so, pull out a few yards of thread until you've gotten rid of the defective thread. If that doesn't work, try replacing the thread with a new cone.
5. Check for defective needles or needles not inserted properly. You will be able to tell if a needle is defective or not positioned correctly by verifying if the problem is on one or some needles and not others. Replace any damage or bent needles.
6. Make sure the bobbin is installed properly. Remove any lint or dirt build-up in the bobbin case. Make sure the thread trimmer knife is fully retracted.
7. If thread breaks are occurring on all the needles, you need to adjust the hook timing. Refer to Adjusting the timing of a needle and hook for details.

TIP: Always do a sew-out on two pieces of backing or on a piece of the same material as the garment. This will help you see if the correct backing, topping and hooping methods have been applied. This will also help you verify if the tension of the thread and bobbin are correct.

NEEDLES

Anatomy of the needle

Shank: The top section of the needle that attaches to the needle bar (into the machine).

Shaft/blade: The part of the needle that ranges from the end of the shank to the top point of the needle.

Taper: The narrowed end of the needle that lies below the eye.

Point: The very bottom of the needle. The part of the needle that pierces through the fabric.

Eye: The opening where the thread passes through the needle.

Groove: The indented surface that runs along the face (front) of the needle.

Scarf: The half-moon-shaped cut out on the back of the needle, located just above the eye.

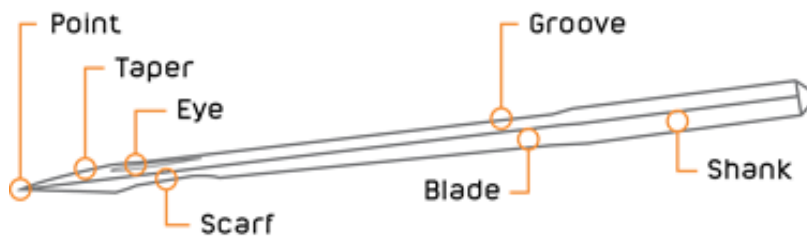

Figure 124

How long do needles last?

There are several factors that determine the lifetime of a needle.

This includes but is not limited to:

- The material the needle is made of
- The style of the needle
- The material you are sewing on
- How often you use the needle

How do I know when to change a needle?

A basic guideline that many professional embroiderers use to determine when to change needles is the “three strikes” rule. When there have been three consecutive thread breaks on a needle, it should be changed. Several performance changes in your machine will indicate when it’s time to change a needle.

This includes but is not limited to:

- Thread breaks
- Poor stitch quality
- Pulls in the fabric
- Machine making unusual noises
- Machine operating at reduced speeds

Why do needles break?

Needles break for a number of reasons.

This includes but is not limited to:

- The needle being worn out or old.
- The design having too many stitches and/or too high density for the design area.
- The fabric inside the hoop area being too loose (the material is not hooped tight enough)
- The needle hitting the hoop
- The movement of fabric while the needle is penetrating

Blade size

One of the first things to consider when selecting a needle is the blade size, such as size 75/11 or 90/14. If you have ever wondered why there are two numbers in this designation, the reason is that it is a combination of the European and American size designation numbering systems. The first number, such as 75 or 90, is the European designation. This refers to the actual measurement of the blade diameter. For example, a size 80 needle has a .80 mm blade width. The second number, such as 11 or 14, is an Asian numbering system, also formerly used by Singer. In this system, a smaller number indicates a smaller blade diameter.

SIZE 75/11

Good overall needle. It is used to sew everyday items like golf shirts, sweatshirts, dress shirts, light jackets, light canvas, aprons, holiday stockings and more.

SIZE 70/10

Good needle for the newer tech garments. It is used to sew moisture management (wicking), anti-bacterial and body temperature management garments, such as t-shirts and golf shirts.

SIZE 65/9 OR 60/8

Good needle for very light or delicate materials. It is used to sew silks and fine linens. It is also used to sew detailed designs on small areas, such as intricate patches or very small lettering.

SIZE 80/12

Good needle for heavy materials. It is used to sew heavy canvas, vinyl, light leather, ball caps, visors and more.

SIZE 90/14

Good needle for metallic thread. It has a larger eye, which allows the thread to easily pass through the eye. It is used to sew canvas and belts too since it is a very stiff needle.

Tip: The point must be able to pierce through the fabric easily to avoid deflecting when the needle contacts the material. Otherwise, the needle will strike the surrounding metal or the needle plate, potentially causing damage to the needle or the machine. Choose a finer blade for more fine-woven or knit fabrics. Use a larger blade for tough fabrics that could cause needle deflection.

Needle finishes

Most sewing and embroidery needles have chromium plating that enhances durability and appearance. Titanium-coated needles are more expensive than chromium-plated needles, but they can last as much as five to seven times longer than their chromium-plated counterparts. These types of needles also reduce thread friction. Reduced thread friction lessens the frequency of thread breaks, and saves time and labor. Titanium needles are a beautiful golden color and are available in the most popular sizes.

Types of needlepoints

In order for the needle to penetrate cleanly through the fabric, it is necessary to choose the correct point type. The types of needlepoints used for commercial embroidery include:

1. Acute round point – designation SPI
 - Has a slender sharp point
 - Used on fabric with high thread counts, microfibers and certain synthetics



Figure 125

2. Normal round point – designation R
 - Has a normal sharp point
 - Used on woven fabrics, including finished caps

3. Light ball point – designation SES
 - Designed to spread yarn in knitted fabrics rather than piercing them to maintain the structural integrity of the knit
 - Most popular needle type and is considered a universal point type
 - Suitable for most knit and woven fabrics.

4. Medium ball point – designation SUK
 - Used to spread heavier yarns such as those used in heavier knitted fabrics.

The difference between sharp point and ball point needles

The two primary point types used for sewing and embroidery are sharp point and ball point.

Sharp point needles are used to sew woven materials. These needles will cut the material when they need to, but often find their way into the existing holes of the fabric, just like the ballpoint needles. Made on a loom, woven materials consist of many individual threads. Therefore, if one thread is broken, other threads will remain intact. Your starter kit comes with sharp point needles.

Tip: We recommend using Groz-Beckert brand needles. The designation for sharp point Groz-Beckert needles is RG.

Ball point needles are used to sew knit materials. These needles are non-cutting and work by finding their way into the holes that already exist in the material. If you get holes on knit material, it will unravel due to the fact that knits are made of one continuous thread.

Tip: We recommend using Groz-Beckert brand needles. The designation for ball point Groz-Beckert needles is FFG.

The relationship between needles and thread

Because the eye of the needle will be smaller or larger depending on the size you choose, you will need to change the size of the thread as well in some cases. For instance, a small 65/9 or 60/8 needle will need a lighter weight thread such as a size 60 thread, which is thinner and can easily pass through the needle's eye. The chart below displays which size needle corresponds with which size thread.

Size of a Needle			Size of a Thread			
U.S.A.	Japan	Germany	Cotton	Silk	Nylon	Rayon
0.25	9	65	70~80	100~120	130~150	70~100
0.27	10	70				
0.29	11	75	50~60	80~100	100~130	100~130
0.32	12	80				
0.34	13	85	50~60	60~70	80~100	130~150
0.36	14	90				

Figure 126

THREAD

The bobbin

When it performs well, we take the bobbin for granted. But when you have trouble with bobbin thread, it confounds all efforts toward efficient production. That's because the bobbin affects all needle bars. This makes it impossible to achieve better sewing by simply switching to another needle. Such a vital element commands closer examination.

You have the choice of winding your own bobbins or buying pre-wound commercial bobbins in disposable cartridges. Self-wound bobbins tend to be inconsistent in the way the thread releases from the spool. For high-speed commercial embroidery machines to function properly, a smooth and consistent release of thread is required. Commercial pre-wound bobbins are a cost-effective and efficient solution to ensure bobbin thread runs smoothly.

On average, bobbin thread usually last for about 35,000 to 42,000 stitches depending on the stitch length of your design. Your Ricoma machine requires a size L bobbin. Polyester bobbin thread is preferred over cotton bobbin thread, as it tends to leave less lint.

There are two types of polyester bobbins: spun and filament.

Spun: In this process, small fibers are spun together to form the thread. We do NOT recommend using spun bobbins, as they have the tendency to shear off and collect under the tension spring of the bobbin case. This may cause tension issues over time.

Filament: Under this process, the thread consists of one long filament. Filament bobbins run cleaner in the bobbin case and are significantly stronger.

Types of bobbin sides

Some bobbins have sides that are designed to support the bobbin as it rotates.

Paper-sided: These are the most common.

Side-less: These bobbins consist entirely of thread and do not have sides for support.

Plastic-sided: Some embroiderers say plastic-sided bobbins rotate more easily in the bobbin case and run smoother.

Magnetic bobbins: Magnetic bobbins do not have sides but have magnets for support. Magna Glide bobbins have a magnet in the center, which helps maintain the consistency of the bobbin thread tension. This can help the bobbin run smoother and prevent birdnesting. When using magnetic bobbins, you may need to take out the gunmetal-colored piece on the bobbin case, known as the brake.

Bobbin fiber choices

COTTON

This fiber isn't exactly a popular choice, but it definitely has its followers. Although not as strong as its synthetic counterparts, cotton is valued for its friendly texture, which allows a wider range of adjustments for bobbin tension settings. One of its downfalls is that it produces too much lint, which has a tendency to collect under the bobbin tension plate. Lint build-up can lead to "springing" the tension plate, causing it to fail to hold any tension on the bobbin thread.

NYLON

Nylon bobbin thread exhibits almost exactly the opposite characteristics from cotton. One advantage of using nylon thread is that very fine nylon is still quite strong, so a bobbin can hold many yards of thin nylon thread. The cons of using nylon thread: Its small diameter and slick texture make it tricky to keep consistent tension on bobbin cases. It is also extremely slippery, which makes it difficult to maintain tension.

CONTINUOUS FILAMENT POLYESTER

This fiber is the most popular among U.S. embroiderers. It is strong, thin, reliable, and does not produce lint. It is known its consistency and high quality. It also allows 127 yards to be held on a standard size "L" bobbin. For this reason, American embroiderers use this bobbin fiber more than any other. Fewer bobbin changes or breaks maintain efficiency because it allows for less machine downtime.

SPUN POLYESTER

Spun polyester has a number of benefits that make it the number one bobbin fiber choice of many. Its texture is similar to cotton, without the lint problem. It is also the most economical. Spun polyester bobbins require less plate pressure. However, they leave a lint build up in the bobbin case, which needs to be removed and maintained.

One reason that it has been overlooked is that many people mistakenly believe that a size "L" bobbin will hold only 94 yards of this thread. While that's true of size 100 spun polyester, several suppliers carry size 120 spun polyester. This size yields 120 yards per bobbin, only seven yards shy of continuous filament polyester.

Top thread fiber choices



Figure 127

Size 60, 70, and 80 threads are lightweight threads. This specialty thread is used on fine fabrics, small delicate details and small fonts. If you are using this type of thread, increase the density by 5 to 10 percent.

Size 30 and 40 threads are medium-weight threads. This specialty thread can be used to fill large embroideries with fewer stitches. If you are using this type of thread, decrease the stitch count by 15 percent. This will save production time. Size 35 threads are commonly used for multi-color threads. Your welcome kit includes size 40 threads.

Size 12 threads are heavyweight threads. This specialty thread creates the look of hand embroidery. If you are using this type of thread, use long floating stitches. There is special set-up time required for this thread. We recommend adjusting the tension when using this type of thread.

RAYON THREAD

Rayon thread is widely used by U.S. embroiderers. It is available in sizes 30, 40 and 60. Rayon is a very beautiful, supple and natural fiber made from cellulose. Its handling properties are superior to other fibers used for embroidery thread, and it looks very rich when sewn onto fabric. Unfortunately, it is not one of the stronger fibers. Even slight equipment problems may cause an unacceptable number of thread breaks when using rayon thread. Rayon is more expensive than other fibers and is susceptible to damage by environmental factors, such as temperature and light. Black and white Rayon threads tend to break more frequently because of the bleaching and dying processes. White is heavily bleached to reach its brilliant white color, and black is weakened by the amount of pigment it must absorb to obtain its rich black color.

TIP: Polyester thread is a great choice for towels and infant items that will be bleached.

POLYESTER THREAD

Years ago, polyester embroidery thread was very hard to handle because this fiber is very stretchy by nature. This resulted in looping, which caused operators to tighten down on tensions. This compounded the problem because this stretched the polyester fiber even more. When the thread's memory caused it to regain its original length, the embroidery was often puckered. Today's polyesters are greatly improved and many have excellent sew-ability. The color ranges have also improved, making it a good choice for embroiderers. It may be too strong for certain lightweight, delicate goods, but its resistance to thread breaks can add to production efficiency. We recommend 100% polyester thread for all embroidery projects.

Polyester is one of the two embroidery fibers that can accept neon dyestuffs. The neon colors that you are using in your shop are very likely to be polyester fiber. With excellent resistance to abrasion and bleaching, polyester thread is a great choice for items that will be subjected to sunlight, chlorine or harsh laundering.

TIP: Polyester is stiffer than rayon, and may require some tension or check spring adjustments. Experiment with different tension settings using the spring lever to make tension suitable for this type of thread.

METALLIC THREAD

Avoided by many embroiderers, metallic threads are sometimes difficult to handle. The good news: This beautiful thread type can be tamed.

This thread is stiffer than other varieties, and it has an interesting construction. Metallic threads are actually a metallic film glued to a nylon or polyester core. The quality varies widely among manufacturers, so we recommend talking to other embroiderers to find a brand that performs well.



Figure 128

If you have experienced difficulty in sewing with metallic threads, try:

- Using a smaller size thread
- Using a needle with a larger eye
- Checking your digitizing
- Making sure the densities are appropriate for metallic threads
- Checking if there are too many short stitch lengths, or small turning stitches

TIP: Buy the best metallic brand on the largest spool you can afford. The larger diameter of the spool produces fewer kinks as it unwinds.

COTTON THREAD

For a homespun look, or when creating small personalization on dress shirts, cotton is ideal. Cotton thread makes it easy to adjust tensions. It also has a matte finish that is sometimes preferred over the shiny finish of other thread types. It is available in a broad range of sizes, from very large to very fine. At one time, it was the favored thread for detailed golf logos. Today, it is used for appliqués that are intended to have a homemade look.

THREAD CONSUMPTION

Thread consumption varies according to the type of stitch being made. Longer stitch lengths, such as long satins or jump stitches, use more top thread than shorter stitch lengths like fill stitches. Using an average mix of stitch types, a 5,000-yard cone yields about 9 million stitches. If the cone costs \$9, this would be about one cent per thousand stitches. Bobbin thread yield is about 25,000 to 30,000 stitches for size “L” bobbins. The amount of yardage per bobbin varies according to the thread type.

STABILIZER

Common stabilizer weights

- a) Lightweight: 1 to 1.5 oz.
- b) Medium-weight: 2 to 2.75 oz.
- c) Heavyweight: 3 to 3.5 oz.

TIP: Embroidery is all about experimenting until you feel comfortable with your design. If necessary, you may use multiple pieces of backing or a combination of different-sized backing.

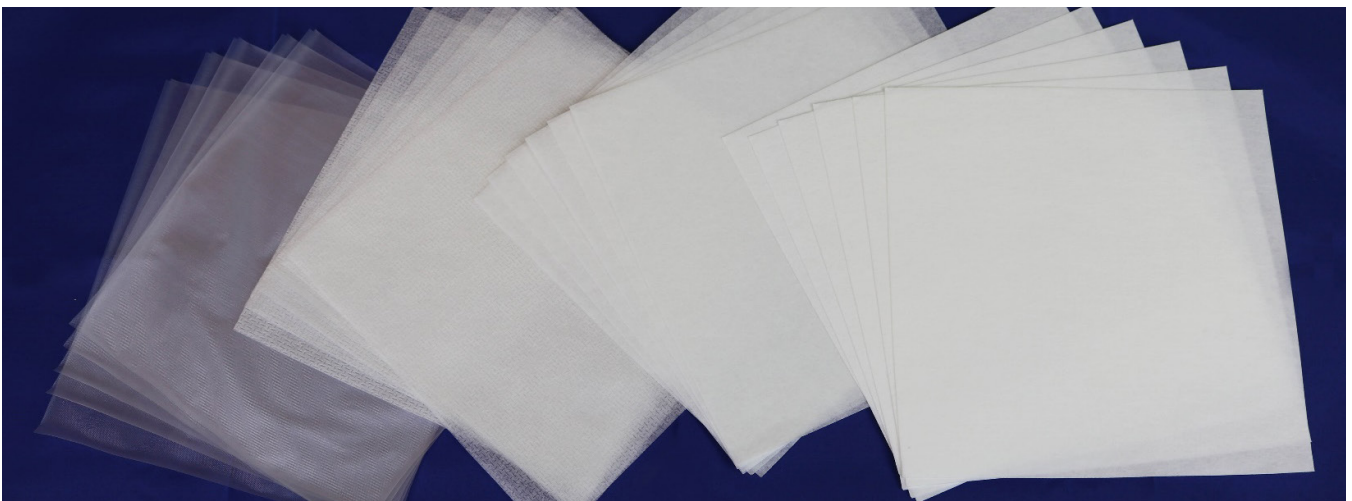

Figure 129

There are several categories of backing used in embroidery. Each has its own use and is suitable for different types of garments.

Cut-away

Cut-away backing is used for permanent support, as it provides the most stability. It comes in light to heavy weights and is heat set fusible. It offers the sharpest embroidery on highly detailed designs, including small lettering. Cut-away backing remains permanently affixed to the fabric, and the excess is cut away with scissors, which is how cut-away backing has earned its name. It is available in 1 oz. (light) to 3.75 oz. (heavy). Cut-away is best used on materials that stretch (such as knits) and fabrics that will be worn and washed frequently, as it prevents the design from stretching. It is also used on loosely woven and unstructured caps. Select a lightweight cut-away for designs with light stitch-density and a heavyweight cut-away for dense designs. If you're not sure if your fabric falls under the "stretchy" category, you can actually feel the fabric to verify. To do so, grab the material with both hands approximately 8 inches apart, and pull on the fabric. Make sure you are in the middle of the fabric, not near an elastic waistband or a zipper. If there is substantial stretching, you should use cut-away backing.

Tear-away

Less stable than cut-away backing, tear-away backing is used for light support. It's available in light to heavy weight and also carries an adhesive version. Like cut-away, tear-away backing is true to its title. Embroiderers tear this backing away from the garment, hence the name. Tear-away backing is typically used on firmly woven, natural-fiber fabrics that don't stretch, such as terry cloth, robes, blankets, leather and more. In addition to being suitable for very strong and stable fabrics, tear-away is also used when you don't want the backing to show on the other side of the design, such as back of towels, caps and bags. When your fabric requires strong support, you may use several layers of lightweight to medium-weight tear-away. This method is easier because you'll remove one lighter sheet at the time, rather than struggling to remove a heavier tear-away.

Specialty backing

Poly mesh or no show backing is a lightweight woven cut-away that is soft, thin and strong. It is designed to provide additional stability to knit shirts. This type of stabilizer does not show through light-colored garments, hence its name. It is used on polo's and T-shirts that will carry designs with a low stitch count. For best results, we recommend combining a no-show backing with a tear-away backing. No-show backing may be removed with water or heat.

Topping

Aqua-top topping is a water-soluble plastic film used on the top of an embroidery design to prevent stitches from sinking into textured fabrics. It is used for temporary support on delicate, mesh-like and

difficult-to-mark fabrics like pique, fleece, terry cloth or corduroy. Topping is also highly recommended when embroidering towels, as it allows the stitches to stand out as much as possible. When using topping, it is still necessary to apply backing on the back of the fabric to stabilize the garment. Topping may be removed by tearing it away, spraying water on it, or a combination of both methods.

Poly mesh backing

While extremely thin, poly mesh backing is exceptionally strong because of the fibers it consists of. This backing is used for adding maximum stability if you don't want to handle the bulkiness of a heavyweight cut-away. Poly mesh is great for the newer tech garments, as they are very thin and have a lot of fluidity to the fabric. Poly mesh will add support without compromising the stability of the garment. An instance where you may use this backing: when embroidering a stretchy tech golf shirt. In this case, you may layer two sheets of poly mesh.

Fusible backing

Fusible backing is used on very stretchy materials. Once fused to the garment, the fabric and the backing become one stable material. It is also used to cover up a finished piece of embroidery, such as an infant's onesie, where the stitches and the backing would otherwise irritate the baby's skin.

Foam

Foam is used to add dimension to lettering or designs on caps for a 3D effect. It is available in a variety of colors in sheets up to 3 millimeters thick. The foam sheet is laid on top of the desired area and then stitched over with a column fill that uses short stitches to cut the foam. The excess foam will need to be pulled away. Some stray pieces of foam that remain can be removed by applying a hot hair dryer over the area.

EMBROIDERY TECHNIQUES

Backing and needle recommendations

CANVAS

- Light to medium tear-away backing
- 75/11 sharp or normal round-point needle
- Sharp needles are better for longer runs

CANTON FLEECE

- Use light tear-away polyester backing to maintain color if a garment is subjected to extensive sunlight, chlorine, salt water or industrial laundering and bleaching.
- 75/11 light ballpoint needle

COATED OR WATERPROOFED FABRICS

- Use a light to heavy tear-away backing
- 75/11 or 80/12 sharp or light ballpoint needle

CORDUROY

- Use a medium topping and light to medium tear-away
- 75/11 light ballpoint needle

DRESS SHIRT (WOVEN)

- Use a heavy cut-away or tear-away/wash-away
- 75/11 or 70/10 light ballpoint needle
- 80/12 needle for small details

GOLF SHIRT

- Use a light to heavy cut-away
- Heavy knits require a medium to heavy cut-away
- Medium knits require a light cut-away
- 75/11 light ball point needle

HEADWEAR

- Use a medium to heavy tear-away
- 75/11 or 80/12 sharp needle

LEATHER AND VINYL

- Use a light tear-away
- 75/11 or 80/12 light ballpoint on stiff or spongy leather (upholstery luggage)
- 70/10 or 80/12 sharp on soft, supple garment leathers

LINGERIE OR SILK

- Use a water-soluble tear-away backing
- 70/10 or 80/12 light ballpoint needle depending on thread

LYCRA OR SPANDEX

- Use a medium cut-away or water-soluble tear-away
- 70/10 medium ballpoint needle

NYLON WINDBREAKER

- Use a light to heavy cut-away
- 75/11 light ball point needle

DENIM

- Use a heavy cut-away or tear-away/wash-away
- 75/11 light ballpoint needle

COTTON SHEETING

- Use a heavy cut-away or tear-away/wash-away
- Cotton-on is great for children's clothing
- 75/11 light ballpoint needle

SATIN JACKET

- Use a light to heavy cut-away
- Cotton-on-cotton is a nice look
- 75/11 light ball point needle

SWEATER KNIT

- Use a medium to heavy cut-away
- 75/11 light ballpoint needle

SWEATSHIRT

- Use a heavy tear-away or cut-away
- 75/11 light ballpoint needle

T-SHIRT

- Use a light, water-soluble tear-away or medium cut-away
- 75/11 light ballpoint needle

TERRY CLOTH

- Use a medium weight, water-soluble tear-away and topping
- 75/11 or 80/12 light ballpoint needles

Hooping placement recommendations

BEACH TOWELS

- Designs should be centered 5 inches above the hem
- Monogram size should be 4 to 5 inches

BATH TOWELS

- Design should be 2 inches above the border or 4 inches above the hem
- Monogram size should be 3 to 4 inches

HAND TOWELS

- Design should be 1 to 1 ½ inches above the border or 2 inches above the hem
- Monogram size should be 2 ½ inches to 3 inches

FINGERTIP TOWELS

- Design should be centered 2 ½ inches from the hem
- Monogram size should be 2 ½ inches

WASHCLOTHS

- Design should be 2 inches above the hem or 1 ½ inches above the border
- Monogram size should be 1 to 2 inches

NAPKINS

- Design should be centered in the corner of the napkin on opposite side of the label
- Monogram size should be 1 to 2 inches

PILLOWCASES

- Design should be placed 3 inches above the hem
- Monogram size should be 1 ¼ to 2 ¼ inches

SHEETS

- Design should be centered 2 inches above the sewn band of the sheet, but sewn on the reverse side so it's visible when the sheet is folded over (many customers prefer full names – especially on children's sheets)
- Monogram size should be 3 inches on hem or 3 to 5 inches above the hem

ROBES – MEN'S

- Design should be 7 to 10 inches from the shoulder seam and 3 to 5 inches from the center

ROBES – WOMEN'S

- Design should be 4 to 6 inches from the shoulder seam and 3 to 5 inches from the center

Specialty hoops



Figure 130

MAGNETIC HOOPS

Magnetic hoops are a great solution for hooping very thick material such as bags. These hoops provide much stronger support to your garment and ensure the fabric is held securely within the hoop. Great for thin materials that are prone to hoop burns (such as satin), these hoops are known to reduce hoop burns, the marks your hoops leave behind on your fabric.

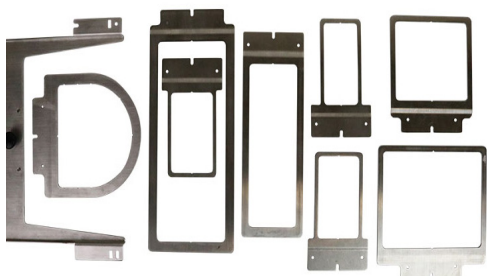

Figure 131

8-IN-1 DEVICE

A solution for difficult-to-hoop items, the 8-in-1 device consists of eight frames that are compatible with one master bracket. These frames are designed to be hooped with adhesive stabilizer, which allows you to embroider your material directly over a thin frame. These narrow frames allow you to get into hard-to-reach areas such as pockets, shirt sleeves and more.

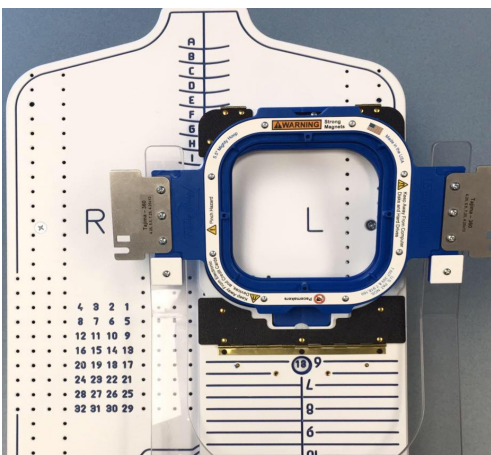

Figure 132

HOOP MASTER

Embroiderers use this hooping board to attain a uniform placement of the hoop and garment to maintain consistency when hooping multiple items. The board holds the outer ring of the hoop. Then, you would place the garment over the board and top it off with the outer hoop ring. The HoopMaster is known to be the easiest to use embroidery hooping aid on the market. Its many patented features make hooping simple, quick and more consistent. Plus, it's custom-made for your hoops, so there is no hardware to adjust.

Cap selection

- Choose a cap that fits your frame. The shape of the visor board inside your cap should match as closely as possible to the curvature of your cap frame. If there are large gaps at the center or sides, registration problems are likely to occur in these locations.
- If the cap doesn't fit your frame, order samples of caps in the styles that you want to try out. Search until you find one that does fit more closely.
- Choose the best cap that your customer's budget will allow. Cheap caps result in high wastage rates, which translate to expensive machine time for which you will not be paid. Also, factor in the extra time that operators spend trying to reach good sewing quality on the cap.

Cap digitizing

- Reduce or eliminate details and outlining where possible.
- Increase column width. The X-axis columns tend to sew narrower on caps than on flat goods.
- Lengthen fill stitch length to reduce needle penetrations and stress on cap. Longer fill stitch length on caps reduces run time.
- Enlarge lettering to at least 3/8" high if possible.
- Digitize in independent sections. Results in more color changes, but improves registration on many designs.

Cap sewing tips

- For best results, apply the appropriate backing. Many embroiderers like to use a 3-ounce tear-away backing and adhesive spray on unstructured caps for better clarity on lettering and detail. On structured caps, use a light to medium-weight tear-away backing depending on the complexity of the design. More complex designs will need heavier backing.
- Topping is beneficial on textured caps like heavy twill and corduroy. It also helps to increase the clarity of designs with small details and lettering.
- You may need to tighten the tension on the bobbin case. Sewing in the round makes bobbin want to pull up to the top side of the work. It helps to use a spun polyester bobbin on caps

because it has more texture and is easier to maintain balanced. Many embroiderers keep a set of cases adjusted for caps.

- When embroidering caps, change needles often. The tough backing on caps dulls needles quickly. Replace the needle about once every for every eight hours of continuous use or when you get three consecutive thread breaks. Titanium needles last longer on caps.



ricoma

THINK BEYOND

RICOMA HEADQUARTERS IN USA

Ricoma International Corporation

3450 NW 114th Ave., Miami, FL 33178, USA

Telephone: (305) 418-4421 | Fax: (305) 418-5036

Toll Free: 1-888-292-6282

www.ricoma.com

info@ricoma.com